

Hunter®

G O L F

ICV Golf Control Valves

ICV

*Superior
Durability, Surge
Resistance and
Serviceability*

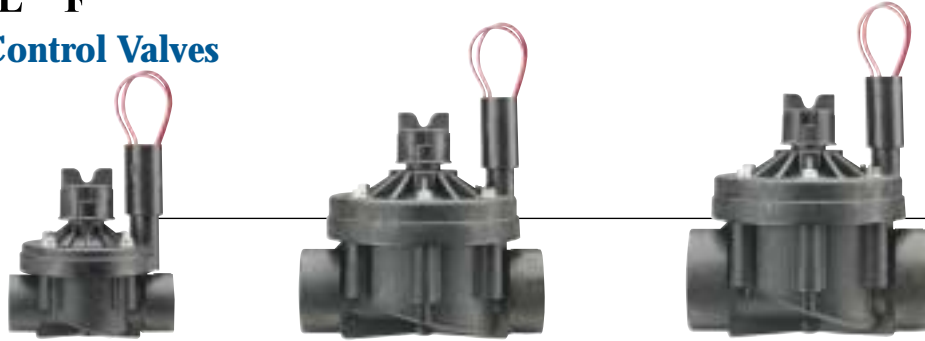

Golf course conditions demand superior durability, long life and easy maintenance. The ICV was designed with these requirements in mind. The result is a valve as rugged, durable and reliable as any valve on the market, even those made from solid brass. The ICV can consistently withstand a pressure rating of up to 200 psi and can handle the continual hammering that such forces will produce. Designed for the wide

range of conditions particular to golf course irrigation, this valve offers a fabric reinforced diaphragm that provides flow control as a standard feature. In addition, the ICV is extremely easy to service, since the valve's bonnet fasteners can be loosened and tightened using a variety of common contractor tools. For a long-lasting valve that can measure up to golf performance specifications, this is the heavy duty workhorse you're after.

FEATURES & BENEFITS

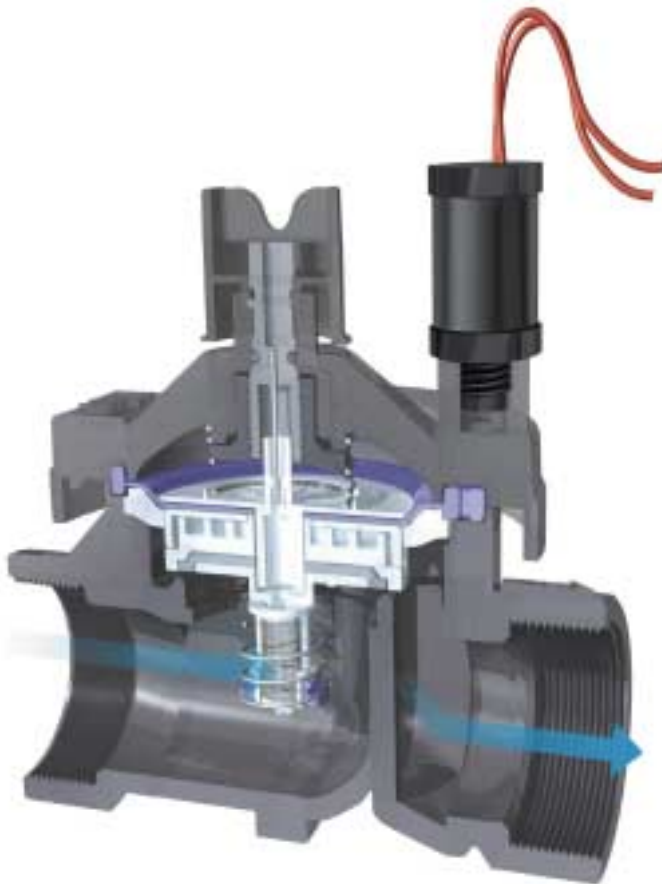

Glass-filled nylon construction

200 psi rated for maximum strength and sturdiness

Internal manual bleed

Keeps valve box dry

Captive solenoid plunger

No more lost parts when servicing

Captive bonnet bolts with matching brass body inserts

Provide ease of service, eliminate lost parts

Fabric reinforced diaphragm

Provides reliable operation up to 200 psi

Optional Filter Sentry™ system

Automatically cleans the filter

Optional Accu-Set™ pressure regulator

Maintains a safe, constant water pressure level

Interchangeable solenoid

Stock one solenoid for all your Hunter Golf products

Models

- ICV-101G – 1" globe valve
- ICV-101G-FS – 1" plastic globe valve with Filter Sentry™
- ICV-151G – 1 ½" plastic globe valve
- ICV-151G-FS – 1 ½" plastic globe valve with Filter Sentry™
- ICV-201G – 2" plastic globe valve
- ICV-201G-FS – 2" plastic globe valve with Filter Sentry™
- Accu-Set™ Pressure Regulator

Dimensions

- ICV-101G – 5 ½" H x 4 ¾" L x 4" W with Accu-Set™, 6 ½"
- ICV-151G – 7 ⅛" H x 6 7/8" L x 5 ½" W with Accu-Set™, 8 1/8"
- ICV-201G – 7 ⅛" H x 6 7/8" L x 5 ½" W with Accu-Set™, 8 1/8"
- Female inlet/outlet: 1", 1 ½" & 2" NPT or BSP

Operating Specifications

- Flow: 0.10 to 200 GPM
- Pressure: 20 to 200 psi
- Temperature: up to 150°F
- Heavy-duty solenoid: 24VAC, 370mA inrush current, 190mA holding current, 60 cycles
- 475mA inrush current, 230mA holding current, 50 cycles
- Accu-Set™: 20 psi minimum operating pressure. Regulates from 20 to 100 psi.

Options Available

- Accu-Set™ Pressure Regulator
- Reclaimed Water ID Handle (part number: 385905)
- Solenoid Conduit Cover (part number: 464322)

Pressure Loss in PSI

GPM	1"	1 ½"	2"
0.10	2		
0.5	2		
1	2		
5	4		
10	3		
15	3		
20	3	1.5	
30	4	1.5	
40	7	1.7	0.8
50		2.2	1.2
60		3.0	1.7
75		3.9	2.4
90		5.5	3.2
100		7.0	4.2
120		10.9	6.5
135		12.7	7.9
150		16.2	9.8
175			13.3
200			17.7

Charts based on full-open flow control position.



Filter Sentry™: Stands Guard Over Tiny Particles of Dirt

Inside every hard-working valve is a filter, designed to keep out dirt. But microscopic particles like minerals and algae can build up on the diaphragm and wreak havoc to even the toughest filters, eventually leading to premature failure of the valve. The solution? Filter Sentry™ — an added option on the Hunter ICV. At work continuously whenever the valve is operating,

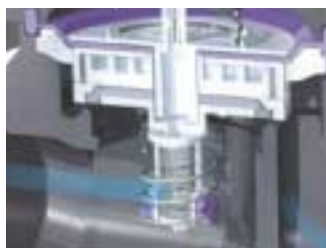

this incredible new scouring mechanism helps keep performance at its maximum by keeping microscopic contaminant build-up to the absolute minimum.

Accu-Set™: Accurately Sets Pressure to be the Same Every Time

What do you do when your irrigation system has to contend with hydraulic surges that far exceed the limits of safe operation? Simply ask for the added option of Accu-Set™ on the new ICV valve and you can reliably adjust and regulate pressures anywhere from 20 to 100 psi, all the while resting easy with the knowledge that the setting you select will be immune to fluctuation.



PRODUCT EXPLANATION

EXAMPLE: **ICV-201G - FS - AS**

MODEL	OPTIONS FACTORY INSTALLED	OPTIONS USER INSTALLED
ICV-101G= 1" Globe valve	FS - Filter Sentry™	AS - Accu-Set™,
ICV-151G= 1 ½" Globe valve	B - BSP Threads	pressure regulator
ICV-201G= 2" Globe valve	DC - DC latching solenoid	CC - Conduit cover