

# **TTS Golf Rotor Owner's Manual**

**Installation, Operation & Servicing Techniques**

for

**G835, G870, G875, G880, G990 & G995 Rotors**



**Hunter<sup>®</sup>**  
**GOLF**

# Table of Contents

<b>Introduction .....</b>	<b>4</b>
<b>Model Numbering System .....</b>	<b>4</b>
<b>Installation and Operation .....</b>	<b>5</b>
Pipe Connections – All Models .....	5
Solenoid Connections – Electric VIH Models .....	6
On-Auto-Off Selection – Electric VIH Models .....	7
Control Tubing Connections – C.O.M Models Converted To Hydraulic Config. ....	8
<b>Riser Servicing and Adjustments .....</b>	<b>9</b>
Upper Snap-ring Removal – G800 Series .....	9
Upper Snap-ring Removal – G900 Series .....	10
Riser Removal – All Models .....	11
Arc Adjustment Preparation – G35, G75 & G95 Part-Circle Risers .....	12
Arc Adjustment Procedure – G35, G75 & G95 Adjustable Part-Circle Risers .....	13
Nozzle Replacement – G70 Risers .....	14
Nozzle Replacement – G35 & G75 Risers .....	15
Nozzle Replacement – G80 Risers .....	17
Nozzle Replacement – G90 Risers .....	19
Nozzle Replacement – G95 Risers .....	21
Riser Seal Replacement – G35, G70 & G75 Risers .....	23
Riser Seal Replacement – G80 Risers .....	25
Riser Seal Replacement – G90 and G95 Risers .....	27
Riser Filter Screen Servicing – All TTS Rotors .....	29
Stator Adjustments – Why and When Are They Needed? .....	29
Stator Adjustments – G35, G70 & G75 Risers .....	30
Stator Adjustments – G80 Risers .....	30
Stator Adjustments – G90 and G95 Risers .....	31
Riser Replacement – Full-Circle Risers .....	32
Riser Replacement – G35, G75 & G95 Adjustable Part-Circle Risers .....	32
Upper Snap-ring Installation Tips .....	33
Upper Snap-ring Installation – G800 Series .....	33
Upper Snap-ring Installation – G900 Series .....	33
<b>Inlet Valve Removal, Service and Installation .....</b>	<b>35</b>
Valve Identification .....	35
Inlet Valve Removal – Disengaging the Safety Interlock Feature .....	37
Inlet Valve Removal – G800 Series .....	38
Inlet Valve Removal – G900 Series .....	41
Inlet Valve Servicing – All Models .....	44
Inlet Valve Installation – Safety Warnings .....	44
Inlet Valve Installation – G800 Series .....	45
Inlet Valve Installation – G900 Series .....	50

<b>Solenoid, Pilot Valve &amp; Regulator Servicing – All Electric VIH Models .....</b>	<b>54</b>
Access To Flange Compartment Components .....	54
Solenoid & Pilot Valve Assembly Removal.....	56
Solenoid & Servicing and Replacement .....	57
Pilot Valve Replacement.....	60
Connecting Solenoid to the Pilot Valve .....	61
Attaching the Assembled Solenoid and Pilot Valve to the Flange Compartment.....	62
Attaching Selector Cap to the Solenoid.....	63
Pressure Regulator Purpose, Settings and Adjustment Procedures.....	64
Pressure Regulator Adjustment.....	65
Pressure Regulator Replacement .....	66
Attaching the Flange Compartment Lid.....	66

## Introduction

Thank you for purchasing Hunter's TTS Golf & Large Turf rotors. TTS rotors include all the features and quality you expect from rotors in this category with the added unique benefit of *Total Top Serviceability*. With Hunter's TTS rotors, *every* serviceable component within the rotor can be accessed from the top *without digging*. So as ongoing routine maintenance is required, the surrounding turf remains playable, productive and pleasing to the eye.

This manual covers all aspects of installation, operation and servicing for Hunter's TTS rotors including models G835, G870, G875, G880, G990 and G995.

For the latest information, specifications and the location of the distributor near you, visit the Hunter Golf website at [www.huntergolf.com](http://www.huntergolf.com). Additionally, Hunter Technical Services can be contacted at 800-733-2823 and choose option #3.

## Model Numbering System

### TTS Rotors – All Models

Hunter TTS golf rotors are available in two basic body styles. These are the G800 Series and the G900 Series rotors. Each of these body styles is available in either the Check-O-Matic valve configuration (C.O.M.) or, the Electric Valve-In-Head (E.V.I.H. or more commonly known as V.I.H.) valve configuration:

G800C = a G800 body in a C.O.M. valve configuration\*

G800E = a G800 body in a V.I.H valve configuration

G900C = a G900 body in a C.O.M. valve configuration\*

G900E = a G900 body in a V.I.H valve configuration

Each body style will accept specific gear-driven risers:

G835 = G800 body style fitted with a G35 full-circle riser

G870 = G800 body style fitted with a G70 full-circle riser

G875 = G800 body style fitted with a G75 adjustable part-circle riser

G880 = G800 body style fitted with a G80 full-circle riser

G990 = G900 body style fitted with a G90 full-circle riser

G995 = G900 body style fitted with a G95 adjustable part-circle riser

Combining a body style, gear-driven riser and valve configuration together creates a model number system that clearly defines the primary characteristics of the rotor:

Examples - G875C = a G800 body with a G75 adjustable riser and a C.O.M. valve

G990E = a G900 body with a G90 full-circle riser and a V.I.H valve

## Installation and Operation

### Pipe Connections – All Models

All TTS rotors have a 1½-inch Acme threaded inlet. Acme inlet threads have become the preferred thread configuration in the golf course irrigation market. **Do Not** use NPT or BSP threaded fittings to connect piping to TTS rotors. Acme threads are not compatible with NPT or BSP fittings. Acme threaded fittings and swing joints are available from your local irrigation supply company. Following are the available options for connecting TTS rotors to the irrigation system piping:

- PVC swing joints with a 1½ inch male Acme outlet fitting.
- Approved flexible swing joints with a 1½ inch male Acme outlet fitting.
- Replace the final fitting of the existing swing joint with a 1½-inch male Acme outlet fitting (fitting must be the same brand as swing joint).
- Use the appropriate Hunter Acme Adapter fitting. These are available from Hunter distributors in various NPT and BSP sizes. (Teflon™ tape or PVC cement must be used between the connecting NPT or BSP threads)

Following are the minimum recommended swing joint sizes for TTS rotors. However, follow your Irrigation Consultant's recommendations where applicable:

- G870 Series rotors – 1¼ inch swing joint with a 1½ inch male Acme outlet fitting
- G880 Series rotors – 1½ inch swing joint with a 1½ inch male Acme outlet fitting
- G990 Series rotors – 1½ inch swing joint with a 1½ inch male Acme outlet fitting

**Do Not** use Teflon™ tape, PVC cement or other thread sealant materials to connect the TTS rotor to the Acme fitting. If needed, a small amount of Dow Corning™ #111 Valve Lubricant or pure petroleum jelly like Vaseline™ can be used around the O-Ring on the Acme fitting. Other lubricants can deteriorate the fitting and cause leakage. Thread the Acme fitting into the G800 Series rotor clockwise until it bottoms out (no further rotation is possible). Then turn the fitting in reverse (counter-clockwise) ½ turn. The fitting will still seal around the O-Ring and this loosened position will allow minor rotation of the rotor's body after installation.



Typical NPT or BSP  
Swing Joint Fitting  
with tapered threads



Typical ACME  
Swing Joint Fitting  
with O-ring seal

## Solenoid Connections – Electric VIH Models

TTS Electric Valve-In-Head models have solenoid lead wires protruding from the rotor's body in the traditional manner. Controller field wires can be connected to the rotor, using the specified watertight wiring connectors, at this sub-surface position. If specified or requested otherwise, the solenoid lead wires and controller field wires can be pulled up into the rotor's flange compartment where the initial connections can be made (recommended). Regardless of the initial connection point, future solenoid repair connections can be made within the flange compartment. (see Solenoid Servicing later in this manual)



Recommended Wiring  
Connections

***Caution! When connecting solenoid leads outside of the flange compartment, DO NOT pull solenoid leads downward in an attempt to provide more exposed solenoid wire. Electric TTS rotors REQUIRE slack in solenoid wiring within the flange compartment to facilitate servicing of the pilot valve and solenoid. Removing the slack can limit movement of the On-Auto-Off selector and require cutting of solenoid wires to service pilot valve and/or solenoid.***



Do NOT Pull On Solenoid  
Lead Wiring

### On-Auto-Off Selection – Electric VIH Models

Electric Valve-In-Head TTS rotors are equipped with a selector to control operation of the rotor. The selector is located on the flange compartment's lid. From the factory, the selector is set to the AUTO position which is located midway between the ON and OFF positions (fig 1).

Several tools are available to make ON-AUTO-OFF selections:

- T-Handle Tool – PN 319100
- Hunter Wrench – PN 471720
- Snap-ring Tool – PN 251000

The ON-AUTO-OFF selector's function and recommended operation is as follows:

**AUTO** – The selector comes from the factory in the AUTO position. When in this position, the rotor will not activate unless the controller sends 24 volts of power to the rotor's solenoid. (fig 1)

**OFF** – Using one of the tools listed above, turning the selector approximately ¼ turn clockwise from the AUTO position will manually deactivate the rotor. In the OFF position, the rotor will not activate even if the controller sends 24 volts of power to the rotor's solenoid. To restore activation by the controller's programming, return the selector to the AUTO position. (fig 2)

**ON** – Using one of the tools listed above, turning the selector ¼ turn counter-clockwise from the AUTO position will manually activate the rotor. The rotor will continue to operate until the selector is returned to the AUTO or Off position. De-activation of the sprinkler may take several seconds. (fig 3)



Fig 1



Fig 2



Fig 3

**Caution! Do not over-tighten the selector when turning to the manual OFF position. Turn only until resistance is felt. Over-tightening can cause premature failure of the solenoid's plunger seal and lead to the rotor leaking water in the AUTO position.**

## Control Tubing Connections – C.O.M Models Converted To Hydraulic Configuration

In hydraulic installations, the flange compartment should be used to make the Control Tubing connections to the rotor. This allows for tubing connections, pressure tests and flushing of the control lines - - all without digging.

*Converting C.O.M. models to the Hydraulic configuration* – Remove the two stainless steel screws and lift the flange compartment lid to expose the flange compartment. Find the end of the 1/8-inch tubing that comes into the flange compartment from the bottom of the rotor (fig 4). Check-O-Matic (“C”) versions of TTS rotors can be converted for use in Normally Open Hydraulic systems by removing the end cap on the 1/8-inch tubing. To do so, slide the ¼-inch tube retainer towards the end of the tube (fig 5). Then, pull to remove the end cap with attached ¼-inch tube retainer from the brass connector fitting (fig 6).

To connect the ¼-inch control tube from the controller to the TTS rotor tubing, insert ¼-inch tubing from controller into the bottom of the flange compartment. Next slide the ¼-inch tube retainer (from end cap supplied with rotor) onto the ¼-inch Control Tubing. Then connect the ¼-inch Control Tubing to the rotor’s 1/8-inch Control Tubing by pressing together at the brass fitting. Finally, slide the ¼-inch tube retainer towards the brass fitting to lock the tube in place.



Fig 4



Fig 5



Fig 6

## Riser Servicing and Adjustments

**Caution!** The riser assembly is under spring tension. Eye protection should be worn and safe-handling procedures followed when servicing this product.

### Tools Needed (varies with riser model)

- T-Handle Tool – PN 319100
- Hunter Wrench – PN 471720
- Snap-ring Tool – PN 251000
- Needle-Nose Pliers
- Flat Blade Screwdriver
- Phillips Screwdriver

### Upper Snap-ring Removal – G800 Series

Hold Snap-ring Tool vertical over the rotor's upper snap ring. Align the metal end of the snap-ring tool to the indicator on the snap-ring's rubberized wiper seal (fig 7). Use the palm of the other hand to drive the tool downward & through the rubberized membrane. Tool should penetrate about ½ inch into the snap-ring assembly (fig 8). While holding the tool within the snap-ring, press the tool's handle downward and away from the center of the rotor. As the tool is pressed downward, the snap-ring will lift from the rotor (fig 9). While using the tool to hold the snap-ring in this elevated position, use the other hand to pull the snap-ring from the rotor. If the snap-ring's rubberized wiper seal appears to be the only part that is lifting, the tool has not penetrated into the snap-ring far enough.



Fig 7



Fig 8



Fig 9

## Upper Snap-ring Removal – G900 Series

Prior to removal of the upper snap-ring assembly, the rubberized logo cap must be removed and the riser assembly must be pressed below the snap-ring's rubberized seal. If the procedure below is not followed, the upper snap-ring assembly cannot be removed from the G900 Series rotors:

Remove the stainless screw from the center of the rubberized logo cap using a Phillips screwdriver (fig 10). Prior to removing the rubberized logo cap, note that the arrows on the logo indicate the position of the nozzles on the riser assembly. As the rubberized logo cap is removed, note there is a protruding pin on the underside of the logo cap (fig 11). This pin is the alignment feature on the rubberized logo cap that must be inserted correctly during assembly in order for the arrows on the rubberized logo cap to be positioned over the nozzles below. Note which hole the pin fits into on top of the riser (fig 12). Also note that the pin and hole locations are different for the G90 and G95 risers.

Once the rubberized logo cap is removed, use the heel on the palm of your hand to forcefully press the riser assembly down (fig 13) and below the rubberized wiper seal on the snap-ring assembly (fig 14). When the rotor is dry (without water within) more force is required. If sprinkler is installed and has been activated, the water acts to lubricate the wiper making the procedure much easier.

To remove the snap-ring assembly, hold Snap-ring Tool vertical over the rotor's upper snap-ring area. Align the metal end of the snap-ring tool to the indicator on the snap-ring's rubberized wiper seal (fig 15). Use the palm of the other hand to drive the tool downward & through the rubberized membrane (fig 16). Tool should penetrate about  $\frac{1}{4}$  inch into the snap-ring assembly. While holding the tool within the snap-ring, press the tool's handle downward and away from the center of the rotor. As the tool is pressed downward, the snap-ring will lift from the rotor. While using the tool to hold the snap-ring in this elevated position, use the other hand to pull the snap-ring from the rotor. If the snap-ring's rubberized wiper seal appears to be the only part that is lifting, the tool has not penetrated into the snap-ring far enough.



Fig 10



Fig 11



Fig 12



Fig 13



Fig 14



Fig 15



Fig 16



Fig 17

### Riser Removal – All Models

To remove the riser assembly, first remove the upper snap ring as outlined above. Insert the Hunter Wrench, T-Handle Tool or tip of the Snap Ring tool into the riser's lift socket, turn ¼ turn and lift the riser from the rotor's body. The lift socket for G870, G875 and G880 models is protected by a rubberized membrane on the rubberized logo cap and can be located by finding the raised line depiction of the socket's shape (fig 18). G990 and G995 risers have a removable rubberized logo cap so the lift up socket is accessed after removing the logo cap, directly on top of the riser (fig 19). In some cases, the riser can simply be pulled from the rotor's body by hand once the upper snap-ring assembly is removed (fig 20).



Fig 18



Fig 19



Fig 20

### Arc Adjustment Preparation – G35, G75 & G95 Part-Circle Risers

All Hunter adjustable arc rotors have a fixed stop on the right side of the arc and an adjustable stop on the left side of the arc. Arc adjustments can be made with the riser in hand or, after installation with the rotor not activated or, while the rotor is in operation. For convenience of installation, new rotors from the factory are set to approximately 180 degrees and the long-range nozzle is positioned to the right fix side of the arc.

Before setting the arc, it is necessary to first establish where the right side fixed arc stop is located:

*With any adjustable riser held in hand* – to expose the rotate-able nozzle housing (also known as the turret), press down on the riser seal assembly to compress the riser's retraction spring (fig 22). Seal assembly must be held in this position. Rotate the nozzle housing back and forth until the right side arc stop is found. This is the fixed (non-adjustable) side of the arc. All adjustments should be made with the nozzle housing in this right stop position.



Fig 22

*With riser installed and rotor not activated* – Lift the riser assembly using the lift socket on the rubberized logo cap (fig 23). The riser must be held in the popped up position with one hand while using the other hand to rotate the nozzle housing. Rotate the nozzle housing back and forth until the right side arc stop is found. This is the fixed (non-adjustable) side of the arc. All adjustments should be made with the nozzle housing in this right stop position. Note that the G35 & G75 turrets can be rotated when the riser is retracted within the body. It is usually possible to find the right fixed arc stop and make arc adjustments to these risers while in the retracted position.



Fig 23

With riser installed and rotor operating (fig 24) – Rotate the nozzle housing back and forth until the right side arc stop is found. This is the fixed (non-adjustable) side of the arc. All adjustments should be made with the nozzle housing in this right stop position.



Fig 24

### Arc Adjustment Procedure – G35, G75 & G95 Adjustable Part-Circle Risers

All adjustments are initiated by inserting the small end of the T-handle tool or the plastic end of the Hunter wrench into the riser's adjustment socket. The adjustment socket can be found on the riser's rubber cover by locating the circular depiction with arrows going in opposite directions (fig 25). Insert the tool through the rubberized membrane to engage the adjustment mechanism. Again, all arc adjustments must be made with the turret oriented to the right fixed side of the arc as outlined in the section above.



Fig 25

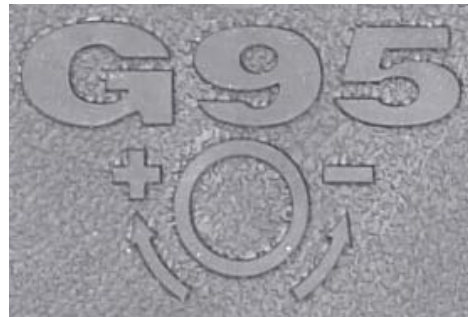

Fig 26

To increase the arc of coverage – insert the tool into the adjustment socket (fig 26) and make sure the nozzle housing is at the right arc stop position. Each full turn of the tool to the right (clockwise) will increase the arc by 45 degrees. Two full turns of the tool will result in a 90-degree increase in the arc of coverage. The arc is infinitely adjustable from 40 to 360 degrees. When maximum arc is reached, the tool will stop turning or, a ratcheting sound will be heard. To check the arc setting, rotate the turret back and forth. If further adjustments are required, repeat the steps above.

To decrease the arc of coverage – insert the tool into the adjustment socket (fig 26) and make sure the nozzle housing is at the right arc stop position. Each full turn of the tool to the left (counter-clockwise) will decrease the arc by 45 degrees. Two full turns of the tool will result in a 90-degree decrease in the arc of coverage. The arc is infinitely adjustable from 40 to 360 degrees. When minimum arc is reached, the tool will stop turning or, a ratcheting sound will be heard. To check the arc setting, rotate the turret back and forth. If further adjustments are required, repeat the steps above.

See “Riser Replacement” section for instructions on aligning right side fixed arc stop to landscape and snap ring installation.

### **Nozzle Replacement – G70 Risers**

To view and replace the nozzles, it is necessary to:

*With riser held in hand* – compress the riser spring by grabbing the riser seal assembly (fig 27), pressing downward and then holding riser firmly to prevent the spring from moving upwards.



Fig 27

***Note – Riser assembly must be removed to changed nozzles. This is necessary since stator setting must also be adjusted when changing nozzles. See section titled, “Stator Adjustments – Why and When Are They Needed”.***

The G70 riser has two color-coded opposing nozzles. All G70 nozzles are retained in the nozzle housing (turret) with setscrews (fig 28). Each setscrew has a 3/32-inch Allen wrench recess at the top. When replacing both G70 nozzles, it is important to note that the nozzles must be the same color. These color-coded sets offer the optimum efficiency for each flow range.

On the G70’s rubberized logo cap, locate the two opposing arrowhead shaped areas directly above the nozzles (fig 29). Insert the metal end of the Hunter wrench or a 3/32 Allen wrench into the membrane within the arrow that is directly above the nozzle to be replaced. Engage the setscrew and turn counter-clockwise until the bottom of the setscrew clears the top of the nozzle.

Note the nozzle's orientation prior to removal to aid in the nozzle installation process. Using needle-nose pliers, grab the right side of the nozzle on its outer ring and pull outward to remove the nozzle. In some cases it may be necessary to grab the nozzle's orifice to remove the nozzle. Discard the old nozzle as the removal process can damage the nozzle and negatively affect the performance.

Insert the replacement nozzle into the nozzle housing with the tab positioned to the right. Press firmly until it stops. Turn the nozzle-retaining setscrew clockwise while making sure that the setscrew does not distort the nozzle. Lower the setscrew in front of the nozzle only as far as necessary to prevent nozzle movement. Take care not to position the setscrew in front of or against the nozzle's orifice as performance can be negatively affected.

If the nozzle size or color has been changed, please note that the adjustable stator will likely need to be reset. Refer to the Stator Adjustment section below for information on how to reset the stator.



Fig 28



Fig 29

### Nozzle Replacement – G35 & G75 Risers

To view and replace the nozzles, it is necessary to compress the riser spring by grabbing the riser seal assembly (fig 27 above), pressing downward and then holding riser firmly to prevent the spring from moving upwards.

The G35 nozzles are yellow with single orifices. The G75 nozzles are color-coded with two orifices. All nozzles are retained in the nozzle housing (turret) with a setscrew (fig 30). Each setscrew has a 3/32-inch Allen wrench recess at the top.

On the G35 or G75 rubberized logo cap, locate the arrowhead shaped area directly above the nozzle (fig 31). Insert the metal end of the Hunter wrench or a 3/32 Allen wrench into the membrane within the arrow that is directly above the nozzle to be replaced. Engage the setscrew and turn counter-clockwise until the bottom of the setscrew clears the top of the nozzle.

Note the nozzle's orientation prior to removal to aid in the nozzle installation process. Using needle-nose pliers, grab the right side of the nozzle on its outer ring and pull outward to remove the nozzle. In some cases it may be necessary to grab the nozzle's orifice to remove the nozzle. Discard the old nozzle as the removal process can damage the nozzle and negatively affect the performance.

Insert the replacement nozzle into the nozzle housing with the smaller orifice positioned to the right. Press firmly until it stops. Turn the nozzle-retaining setscrew clockwise while making sure that the setscrew does not distort the nozzle. Lower the setscrew in front of the nozzle only as far as necessary to prevent nozzle movement. Take care not to position the setscrew in front of or against the nozzle's orifice as performance can be negatively affected.

If the nozzle size or color has been changed, please note that the adjustable stator will likely need to be reset. Refer to the Stator Adjustment section in this manual for information on how to reset the stator.



Fig 30



Fig 31

## Nozzle Replacement – G80 Risers

To view and replace the nozzles, it is necessary to compress the riser spring by grabbing the riser seal assembly (fig 32), pressing downward and then holding riser firmly to prevent the spring from moving upwards.



Fig 32

The G80 riser has three color-coded opposing nozzles. All G80 nozzles are retained in the nozzle housing by the shroud (fig 33) that covers the nozzle housing (turret). To remove the shroud, use a Phillips head screwdriver and remove the stainless steel screw at the top of the riser by turning it counter-clockwise. Prior to removal of the shroud, take note that the large nozzle arrow on top of the shroud's rubberized logo cap is orientated directly over the larger, long-range nozzle (fig 34). This will help with the shroud installation process later.



Fig 33



Fig 34

While firmly holding the compressed spring and seal assembly downward, grab and lift the shroud off the nozzle housing (fig 35). If preferred, slowly lift and release the compressed spring and seal assembly then remove them from the riser assembly. Note the orientation of the seal assembly for installation later. Or alternatively, continue to firmly hold the compressed spring and seal assembly downward while removing and replacing nozzles.

To remove the G80 long-range primary nozzle, use needle-nose pliers to grab the nozzle's orifice then pull outward (fig 36). Discard the old nozzle as the removal process can damage the nozzle and negatively affect the performance. Prior to nozzle replacement, note that there is a notch (recessed area) on the nozzle's outer ring. Insert the replacement nozzle into the nozzle housing with this recess positioned at the top. The correct orientation of the recessed area is important as it is part of the G80's nozzle retention system. Press in firmly until the nozzle stops.



Fig 35



Fig 36

The G80's short-range and mid-range nozzles are performance matched to all G80 long-range nozzles. As a result, replacement of these nozzles is normally required only when a nozzle has been damaged. If replacement does become necessary, it is important to note that these nozzles must be installed with the correct orientation for optimal performance.

Prior to removal of the short-range or mid-range nozzle, note the differences between the nozzle on the left and right. When facing the short-range and mid-range nozzles:

- G80 Full Circle - The short-range nozzle is black and on the right side  
- The mid-range nozzle is blue and on the left side.

To remove the short or mid-range nozzle, grab and rotate the nozzle 90 degrees to the outside (away from turret) then wiggle and pull it upward. To install a short-range or mid-range nozzle, position the nozzle so the orifice is pointing outward and to the side. Drop the nozzle into position by wiggling it downward. The final step is to rotate the nozzle 90 degrees pointing it in the opposite direction of the primary long-range nozzle. This action locks the nozzle in the nozzle housing.

Prior to installation of the shroud, replace the retraction spring and seal assembly (if removed prior). To install the nozzle housing shroud, position the shroud over the nozzle housing. The single opening for the Primary long-range nozzle in the shroud must be positioned directly over the nozzle. Press into position and confirm all three nozzle openings are lined up with the nozzles inside. Install the stainless steel screw into the rubberized logo cap by turning it clockwise until hand tight.

If the nozzle size or color has been changed, please note that the adjustable stator will likely need to be reset. Refer to the Stator Adjustment section in this manual for information on how to reset the stator.

### **Nozzle Replacement – G90 Risers**

To view and replace the nozzles, it is necessary to compress the riser spring by grabbing the riser seal assembly (fig 37), pressing downward and then holding riser firmly to prevent the spring from moving upwards.



Fig 37

The G90 riser has three color-coded opposing nozzles. All G90 nozzles are retained in the nozzle housing (turret) with three setscrews (figs 38 & 39). Each setscrew has a 3/32-inch Allen recess at the top. Insert the metal end of the Hunter wrench or a 3/32 Allen wrench into setscrew that is above the nozzle to be replaced. Engage the setscrew and turn counter-clockwise until the bottom of the setscrew clears the top of the nozzle.



Fig 38



Fig 39

To remove the long-range primary nozzle, first note the nozzle's orientation prior to removal. The G90's primary nozzle has a protruding rail that must engage the slot on the right side of the nozzle opening. Understanding this will help during the installation process later. Using needle-nose pliers, grab the nozzle's outer ring next to the recess on the right side of the nozzle opening and then pull outward. If necessary, grab the nozzle's orifice to gain a better grip. Discard the old nozzle as the removal process can damage the nozzle and negatively affect the performance.

Insert the replacement nozzle into the nozzle housing. Press firmly until the nozzle stops. Turn the nozzle-retaining setscrew clockwise while making sure that the setscrew does not distort the nozzle. Lower the setscrew in front of the nozzle only as far as necessary to prevent nozzle movement. Take care not to position the setscrew in front of or against the nozzle's orifice as performance can be negatively affected.

If the nozzle size or color has been changed, please note that the adjustable stator will likely need to be reset. Refer to the Stator Adjustment section in this manual for information on how to reset the stator.

The G90's short-range and mid-range nozzles are performance matched to all G90 long-range nozzles. As a result, replacement of these nozzles is normally required only when a nozzle has been damaged. If replacement does become necessary, it is important to note that these nozzles must be installed in the correct orientation for optimal performance.

Prior to removal of the G90's short-range or mid-range nozzle, note the differences between the nozzle on the left and right.

- G90 Full Circle - The short-range nozzle is black and on the left side. (fig 39)
  - The mid-range nozzle is blue and on the right side. (fig 39)

Note: In 2010, the short-range nozzle will change to red.

Using needle-nose pliers, grab the nozzle's orifice then pull outward. Discard the old nozzle as the removal process will damage the nozzle and negatively affect the performance. Insert the replacement nozzle into the nozzle housing and press firmly until it stops. Turn the nozzle-retaining setscrew clockwise to a position in front of the nozzle that prevents nozzle movement. Take care not to position the setscrew in front of or against the nozzle's orifice as performance can be negatively affected.

### Nozzle Replacement – G95 Risers

To view and replace the nozzles, it is necessary to compress the riser spring by grabbing the riser seal assembly (fig 37), pressing downward and then holding riser firmly to prevent the spring from moving upwards.

The G95 riser has three color-coded nozzles that all face the same direction. All G95 nozzles are retained in the nozzle housing (turret) with three setscrews (fig 40). Each setscrew has a 3/32-inch Allen recess at the top. Insert the metal end of the Hunter wrench or a 3/32 Allen wrench into setscrew that is above the nozzle to be replaced. Engage the setscrew and turn counter-clockwise until the bottom of the setscrew clears the top of the nozzle (fig 41).



Fig 40



Fig 41



Fig 42

To remove the long-range primary nozzle, first note the nozzle's orientation prior to removal. The G95's primary nozzle has a protruding rail that must engage the slot on the right side of the nozzle opening. Understanding this will help during the installation process later. Using needle-nose pliers, grab the nozzle's outer ring next to the recess on the right side of the nozzle opening and then pull outward (fig 42). If necessary, grab the nozzle's orifice to gain a better grip. Discard the old nozzle as the removal process can damage the nozzle and negatively affect the performance.

Insert the replacement nozzle into the nozzle housing. Press firmly until the nozzle stops. Turn the nozzle-retaining setscrew clockwise while making sure that the setscrew does not distort the nozzle. Lower the setscrew in front of the nozzle only as far as necessary to prevent nozzle movement. Take care not to position the setscrew in front of or against the nozzle's orifice as performance can be negatively affected.

If the nozzle size or color has been changed, please note that the adjustable stator will likely need to be reset. Refer to the Stator Adjustment section in this manual for information on how to reset the stator.

The G95's short-range and mid-range nozzles are performance matched to all G95 long-range nozzles. As a result, replacement of these nozzles is normally required only when a nozzle has been damaged. If replacement does become necessary, it is important to note that these nozzles must be installed in the correct orientation for optimal performance.

Prior to removal of the G95's short-range or mid-range nozzle, note the differences between the nozzle on the left and right.

- G95 Adj. Arc - The short-range nozzle is black and on the left side. (fig 40)  
- The mid-range nozzle is green and on the right side. (fig 40)

Note: In 2010, the short-range nozzle will change to red.

Using needle-nose pliers, grab the nozzle's orifice then pull outward. Discard the old nozzle as the removal process will damage the nozzle and negatively affect the performance. Insert the replacement nozzle into the nozzle housing and press firmly until it stops. Turn the nozzle-retaining setscrew clockwise to a position in front of the nozzle that prevents nozzle movement. Take care not to position the setscrew in front of or against the nozzle's orifice as performance can be negatively affected.

## **Riser Seal Replacement – G35, G70 & G75 Risers**

The G35, G70 and G75 riser seal assemblies and the compressed retraction spring are retained on the risers with the rubberized logo cap assembly. It is necessary to remove the rubberized logo cap assembly in order to replace the riser seal assembly. To remove the rubberized logo cap assembly, it is necessary to fully compress the riser spring by grabbing the riser seal assembly (fig 43), pressing downward and then holding riser firmly to prevent the spring from moving upwards.

***Caution! The riser assembly is under spring tension. Eye protection should be worn and safe-handling procedures followed when servicing this product.***

Hold the riser seal assembly down with one hand. Using the other hand, locate the two hidden screws that retain the rubberized logo cap assembly. These can be found by pressing down on the rubberized logo cap close to the “H” and the “r” on the Hunter logo (figs 44 & 45). The Phillips headed retaining screws are directly beneath these depressions. Insert the Phillips screwdriver through the rubberized membrane and engage each retaining screw. Turn counter-clockwise to remove each screw.

Prior to removing the rubberized logo cap assembly, note its orientation as it relates to the nozzles below. This will help with the assembly process later. Remove the rubberized logo cap and set aside.

While still holding the compressed riser seal assembly and retraction spring with one hand, use the other hand to grasp the bottom of the riser assembly. Slowly release the compression of the retraction spring until it is fully extended and no pressure is felt.

Prior to removing the riser seal assembly, note the orientation and sequence of the three individual seal assembly parts (fig 46). The Upper Seal Support is on top and its lower surface nests perfectly with the top of the riser seal. The Riser Seal is the rubberized part in the middle. The Lower Seal Support (also known as the Upper Spring Support) has an upper surface that nests perfectly to the lower surface of the Riser Seal. The Support's lower surface also provides a nest for the retraction spring. During assembly, these three parts must keep this sequence and orientation in order for the seal assembly to function properly.

If any one of the three parts in the seal assembly needs replacement, it is highly recommended that all three components be replaced. To re-assemble the riser, place the seal assembly on top of the retraction spring and then compress. While firmly holding the retraction spring and seal assembly down, place the logo cap assembly on top of the riser in the correct orientation. Insert the two stainless-steel screws through the rubberized membranes on the logo cap and hand tighten with a Phillips screwdriver.

Fig 43



Fig 44



Fig 45

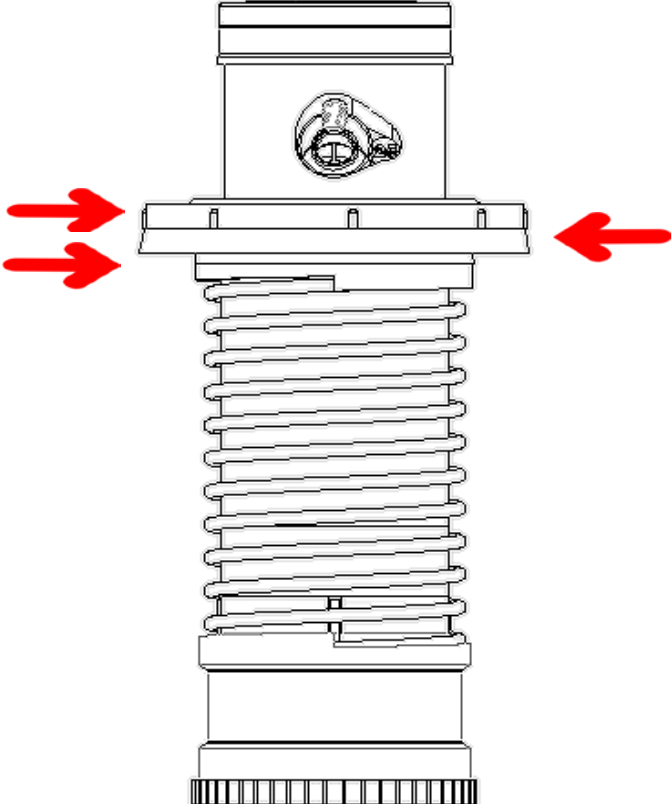

Fig 46

### Riser Seal Replacement – G80 Risers

The G80 riser seal-block assembly and the compressed retraction spring are retained on the riser with the shroud/logo-cap assembly. It is necessary to remove this assembly in order to service the G80's riser seal components. To remove the shroud/logo-cap assembly, it is necessary to fully compress the riser spring by grabbing the riser seal-block assembly, pressing downward and then holding riser firmly to prevent the spring from moving upwards (fig 47).

**Caution! The riser assembly is under spring tension. Eye protection should be worn and safe-handling procedures followed when servicing this product.**

Press the riser seal-block assembly down with one hand and hold firmly. Locate the stainless-steel retaining screw on top of the shroud/logo-cap assembly (fig 48). Use a Phillips screwdriver to engage the screw and turn counter-clockwise to remove. Prior to removal of the shroud, take note that the large nozzle arrow on top of the shroud's rubberized logo cap is orientated directly over the larger, long-range nozzle. This will help with the shroud installation process later.

While firmly holding the compressed spring and seal-block assembly downward, grab and lift the shroud off the nozzle housing then set it aside (fig 49). Slowly lift to release the spring compression. Note the orientation of the seal-block assembly for installation later (fig 50). Next, remove the seal-block assembly and retraction spring.



Fig 47

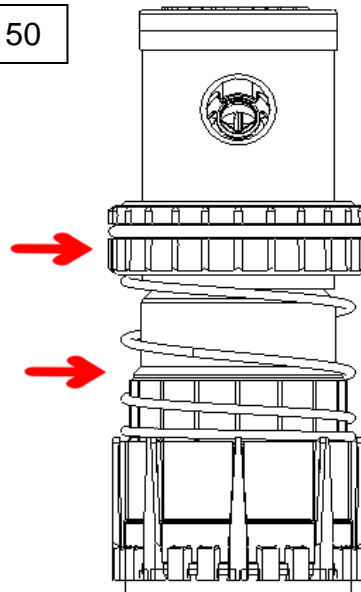

Fig 48

Fig 49



Fig 50



The riser seal on G80 risers include two primary components - - - the seal block assembly and the face-seal. The seal block assembly sits on top of the retraction spring and has two sealing surfaces. First, the seal block has an o-ring around the outside. If the o-ring is damaged, deteriorated or missing, the riser will leak water while the sprinkler is operating. The second sealing surface on the seal-block assembly is on the underside. The angled surface on the underside of the seal-block assembly is the interface for the face-seal. If this angled interface surface is cut or otherwise damaged, the riser can leak water during sprinkler operation.

The face-seal is the second primary component to the G80's riser seal design. The face-seal is the white plastic angled ring that is position at the base of the stainless-steel portion of the G80's riser. If the face-seal is damaged, deteriorated or missing, the riser will leak during sprinkler operation.

If the riser is leaking during sprinkler operation, the o-ring, the interface and the face-seal must be inspected in order to determine the cause of the leakage. If the o-ring is damaged, it can easily be replaced by removing the damaged o-ring from the seal-block and replacing it with a new one. Use care to ensure that the o-ring is not cut or twisted during the installation process. If the interface is damaged, the entire seal-block must be replaced. Also, if the interface is damaged it is highly likely that the face-seal is damaged as well and needs replacement.

To replace the face-seal, slide it upwards and off the riser assembly. Replacement face-seals must fit very snug to the stainless-steel on the riser. As a result, there may be considerable resistance when attempting to install the new face-seal. To make installation easier, the face-seal's diameter can be expanded by placing it in the sun for several minutes. Or, if the repair is being done in the shop, placing the face-seal in warm water for several minutes will cause expansion as well.

Slide the new face-seal down and onto the riser. Make sure that it is pressed all the way until it is seated firmly against the ledge at the base of the stainless-steel portion of the riser. Install the retraction spring and seal-block assembly onto the G80 riser. Press down on the seal-block to compress the retraction spring and hold firmly in this position.

To install the nozzle housing's shroud/logo-cap assembly, position it over the nozzle housing. The single opening for the Primary long-range nozzle in the shroud must be positioned directly over the long-range (largest) nozzle. Press into position and confirm all three nozzle openings are lined up with the nozzles inside. Install the stainless steel screw into the rubberized logo cap by turning it clockwise until hand tight.

### **Riser Seal Replacement – G90 and G95 Risers**

The G90 and G95 riser seal assembly and the compressed retraction spring are retained on the riser with the retainer cap (plastic plate) at the top of the riser assembly. It is necessary to remove the retainer cap in order to replace the riser seal components. To remove the retainer cap, fully compress the riser spring by grabbing the riser seal assembly (fig 51), pressing downward and then holding riser firmly to prevent the spring from moving upwards.

***Caution! The riser assembly is under spring tension. Eye protection should be worn and safe-handling procedures followed when servicing this product.***

Hold the riser seal assembly down with one hand. Locate the two screws that hold the retainer cap to the riser assembly (fig 52). Use a Phillips screwdriver to engage each retaining screw and turn counter-clockwise to remove. Prior to removing the G90 or G95 retainer cap, note its orientation as it relates to the nozzles below. This will help with the assembly process later. Remove the retainer cap and set aside.

While still holding the compressed riser seal assembly and retraction spring with one hand, use the other hand to grasp the bottom of the riser assembly. Slowly release the compression of the retraction spring until it is fully extended and no pressure is felt. Note the orientation of the riser components to help with assembly later (fig 53).

The riser seal on G90 and G95 risers include two primary components - - - the seal block assembly and the face-seal. The seal block assembly sits on top of the retraction spring and has two sealing surfaces. First, the seal block has an o-ring around the outside. If the o-ring is damaged, deteriorated or missing, the riser will leak water while the sprinkler is operating. The second sealing surface on the seal-block assembly is on the underside. The angled surface on the underside of the seal-block assembly is the interface for the face-seal. If this angled interface surface is cut or otherwise damaged, the riser can leak water during sprinkler operation.

The face-seal is the second primary component to the G90 and G95 riser seal design. The face-seal is the white plastic angled ring that is position at the base of the riser. If the face-seal is damaged, deteriorated or missing, the riser will leak during sprinkler operation.

If the riser is leaking during sprinkler operation, the o-ring, the interface and the face-seal must be inspected in order to determine the cause of the leakage. If the o-ring is damaged, it can easily be replaced by removing the damaged o-ring from the seal-block and replacing it with a new one. Use care to ensure that the o-ring is not cut or twisted during the installation process. If the interface is damaged, the entire seal-block must be replaced. Also, if the interface is damaged it is highly likely that the face-seal is damaged as well and needs replacement.

To replace the face-seal, slide it upwards and off the riser assembly. Replacement face-seals must fit very snug to the stainless-steel on the riser. As a result, there may be considerable resistance when attempting to install the new face-seal. To make installation easier, the face-seal's diameter can be expanded by placing it in the sun for several minutes. Or, if the repair is being done in the shop, placing the face-seal in warm water for several minutes will cause expansion as well.

Slide the new face-seal down and onto the riser. Make sure that it is pressed all the way until it is seated firmly against the ledge at the base of the riser. Install the retraction spring and seal-block assembly onto the riser. Press down on the seal-block to compress the retraction spring and hold firmly in this position. While firmly holding the retraction spring and seal assembly down, place the retainer cap on top of the riser in the correct orientation. Insert the two stainless-steel screws and hand-tighten with a Phillips screwdriver.



Fig 51



Fig 52

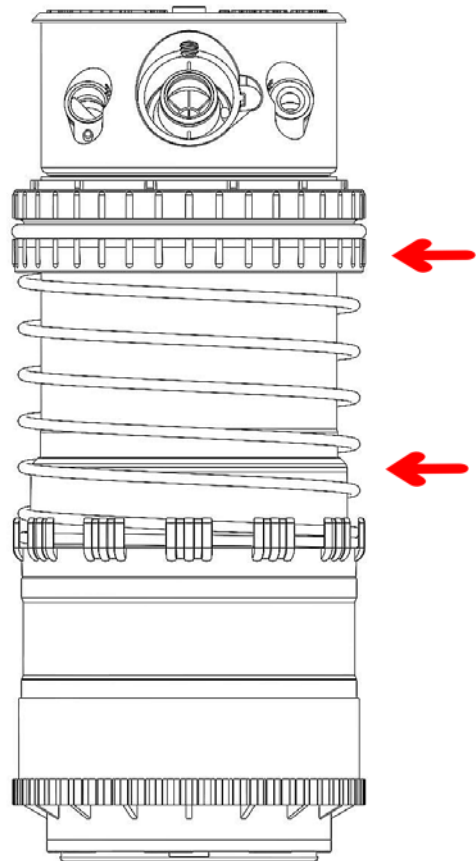

Fig 53

### Riser Filter Screen Servicing – All TTS Rotors

The riser filter screen is located at the base (bottom) of each riser. The purpose of the filter screen is to prevent entry of debris that are too large to exit the riser through the nozzles. If the filter becomes clogged with debris, water flow through the riser can be severely reduced and lead diminished sprinkler performance.

To remove the filter screen, locate the notched recessed area located on the outside where it meets the bottom of the riser. Insert the snap-ring tool or a flat bladed screwdriver into the recess and then twist to lift the filter screen from its position against the riser. Flush filter screen with water to remove debris. To install filter screen, press firmly into position against the riser.



Fig 54  
G35, G70 & G75 Screen



Fig 55  
G80 Screen



Fig 56  
G90 & G95 Screen

### Stator Adjustments – Why and When Are They Needed?

The adjustable stator is preset at the factory to match the nozzle installed in the rotor. The purpose of the stator is to maintain a consistent and desirable speed of rotation. Rotors that turn too fast cannot reach their published radius distance. Rotors that turn too slow will irrigate with a higher precipitation rate per revolution causing wet spots and run-off.

If nozzles are changed to a flow greater than the original factory nozzle, the speed of rotation will become faster unless the appropriate stator adjustments are made. This is because there is a greater amount of water passing the turbine that drives the gearbox. The opposite is true if a smaller flow nozzle is installed without adjusting the stator - - the rotor will slow down. In extreme situations, the rotor may not rotate at all if the stator is not adjusted. Again, stator adjustments are not required unless the nozzle flow is being changed or, the stator was set incorrectly at some point in time.

Setting the stator is as simple as matching the stator setting number to the nozzle number being used in the rotor. For example, if the nozzle in use is #20, then the stator setting will be #20. To access the stator adjustment, first remove the riser's filter screen as outlined in the section above.

### Stator Adjustments – G35, G70 & G75 Risers

Turn the riser upside down, remove the filter screen and view the stator area. Notice the black part with the three sections extending outward from the center (fig 57). This black part on G70 and G75 risers is called the adjustable stator plate. Beneath the adjustable stator plate is a gray non-removable part with the three openings. This part is called the stator. The stator has a series of numbers engraved into the plastic. These numbers are the nozzle size reference numbers.

To make an adjustment, use the blade end of the snap-ring tool or a bladed screwdriver to lift the adjustable stator plate off the stator. To do so, place the tool under one of the two tabs on the post at the center of the stator (fig 58). Pry the tab upward and the stator plate will snap off.



Fig 57



Fig 58



Fig 59

To reset and install the adjustable stator plate, notice the small cutout on each of the three sections of the adjustable stator plate. Next, on the stator find the nozzle number that is being used. Simply align any one of the cutouts on the adjustable stator plate with the desired nozzle number on the gray stator (fig 59). Then, snap the adjustable stator plate down into position. Once the stator plate is installed, check to make sure the desired nozzle number is visible in the cutout window. Finally, install the filter screen as outlined above.

### Stator Adjustments – G80 Risers

Turn the riser upside down, remove the filter screen and view the stator area. Notice the black part with the three sections extending outward from the center (fig 60). This black part on G80 risers is called the adjustable stator plate. Beneath the adjustable stator plate is a gray non-removable part with the three openings. This part is called the stator. The stator has a series of numbers engraved into the plastic. These numbers are the nozzle size reference numbers.

To make an adjustment, rotate the adjustable stator plate to the right in a clock-wise direction (fig 61). Notice the small cutout or “window” on the adjustable stator plate. As the adjustable stator plate is rotated, the various nozzle reference numbers will appear in the cutout/window. Simply keep rotating the adjustable stator plate until the desired nozzle number on the gray stator appears in the cutout/window. Double-check to make sure the desired nozzle number is visible in the cutout/ window. Finally, install the filter screen as outlined in the filter screen servicing section above.



Fig 60



Fig 61

### **Stator Adjustments – G90 and G95 Risers**

Turn the riser upside down, remove the filter screen and view the stator area. Notice the white plastic part that is set within the bottom of the riser (fig 62). This white part on G90 and G95 risers is called the adjustable stator plate. Beneath the adjustable stator plate is a black non-removable plastic part with the opening in the center for the turbine and the single opening to the side. This part is called the stator. The outer ring at the base of the riser has recessed notches all the way around it. Notice that the white adjustable stator plate has a protrusion that is engaged with one of these recessed notches. This protrusion is the adjustable stator plate’s pointer. Also notice there is a series of numbers engraved into the plastic next to some of the recessed notches. These numbers are the nozzle size reference numbers.

To make an adjustment, first find the raised wall or blade of plastic on the adjustable stator plate. Use pliers to grab the plastic blade then pull to remove the white adjustable stator plate from the riser (fig 63). To reset and install the adjustable stator plate, find the nozzle size reference number on the outer ring that matches the installed nozzle. Simply align the pointer on the adjustable stator plate with the desired nozzle number on the outer ring. The pointer can be placed on either side of the nozzle reference number (fig 64). Next, snap the adjustable stator plate down and into position. Once the adjustable stator plate is installed, check to make sure the desired nozzle size reference number aligned with the pointer. Finally, install the filter screen as outlined above.



Fig 62



Fig 63



Fig 64

### **Riser Replacement – Full-Circle Risers**

Full-circle riser assemblies can be inserted into the rotor's body without regard to arc orientation. Insert the riser, screen first, into the rotor's body until it comes to a stop. Next, install the upper snap-ring referencing instructions below for your rotor model.

### **Riser Replacement – G35, G75 & G95 Adjustable Part-Circle Risers**

Adjustable part-circle risers must be inserted such that the arc setting aligns to the area to be irrigated. All Hunter adjustable arc rotors have a fixed stop on the right side of the arc and an adjustable stop on the left side of the arc. Rotate the nozzle housing (turret) back and forth to find the right fixed stop. With the riser positioned to the right fixed arc stop, oriented and point the long-range nozzle to the right side of the landscape area to be irrigated. Drop the riser into position within the rotor's body.

For convenience of installation, new rotors from the factory are set to approximately 180 degrees and the long-range nozzle is positioned to the right fix side of the arc. Arc adjustments can be made with the riser in hand or, after installation – dry or, while the rotor is in operation.

Refer to the section earlier in this manual to learn more about the arc adjusting procedures.

### Upper Snap-ring Installation Tips

Hunter Golf TTS rotors have upper snap-rings with an integrated wiper to help protect the riser and riser seal from external contamination. It is important to follow these installation instructions to maximize the effectiveness of this design.

First, it is important align snap-rings so that the open end of the snap-ring is not adjacent to (next to) the flange compartment. This will become very important the next time the snap-ring is removed. If the flange compartment lid has been removed and the open end of the snap-ring is adjacent to (next to) the flange compartment, it will be very difficult to remove the snap-ring using the snap-ring tool. For better leverage when removing the snap-ring, always align the open end of the snap-ring in a position that is opposite from the body's flange compartment.

The second tip for upper snap-ring installation is about the rubberized flaps at each end of the snap-ring. To ensure that these rubberized flaps lie flat after installation, it is important install the snap-ring correctly. Once installed, the flap on the left end of the snap-ring must be under the flap on the right-side end of the snap-ring.

### Upper Snap-ring Installation – G800 Series

Hold the snap-ring in front of you with the wiper seal facing up and the snap-ring open ends at the top. The snap-ring end on the left must be installed first (fig 65). Lay the snap-ring on top of the rotor and use the left thumb to force the left open end of the snap-ring into the upper snap-ring groove within the body (fig 66). Once engaged, the remaining portion of the snap-ring can be installed by pressing in a counter-clockwise motion around the snap-ring (fig 65).



Fig 65



Fig 66



Fig 65

### Upper Snap-ring Installation – G900 Series

Hold the snap-ring in front of you with the wiper seal facing up and the snap-ring open ends at the top. The snap-ring end on the left must be installed first. Lay the snap-ring on top of the rotor and use the left thumb to force the left open end of the snap-ring into the upper snap-ring groove within the body (fig 66). Once engaged, the remaining portion of the snap-ring can be installed by pressing in a counter-clockwise motion around the snap-ring (fig 67).

Prior to installing the rubberized logo cap, the riser assembly must be pulled up above the upper snap-ring's rubberized seal. If this procedure is not followed, the rubberized logo cap's stainless steel screw cannot reach the riser assembly below and attachment will be impossible.

To pull the riser assembly above the upper snap-ring's wiper seal, first locate the lift-up socket on top of the riser assembly. Using the T-Handle Tool or Snap-ring Tool or Hunter Wrench, insert the tool into the lift-up socket, turn  $\frac{1}{4}$  turn (fig 67). Next, lift the riser assembly up until the nozzles can be seen above the upper snap-ring assembly (fig 68). Slowly release the riser assembly downward until the riser assembly rests on top of the upper snap-ring assembly (fig 69).

As the rubberized logo cap is installed, note there is a protruding pin on the underside of the rubberized logo cap (fig 70). This pin is the alignment feature on the rubberized logo cap that must be oriented and inserted into the riser assembly correctly. Proper alignment and installation of the protruding pin allows the nozzle direction arrows on the rubberized logo cap to be positioned over the nozzles below. Note which hole in the top of the riser that the pin fits into (fig 71). Also note that the pin and hole locations are different for the G90 and G95 rotors.

Install the rubberized logo cap using a Phillips screwdriver. Tighten the stainless screw clockwise until the screw is hand tight. Do not over-tighten.



Fig 66



Fig 67



Fig 68



Fig 69



Fig 70



Fig 71

## Inlet Valve Removal, Service and Installation

**Caution!** *Electric valve-in-head rotors are connected to pressurized main-line or sub-main piping. This pressurized piping must be depressurized before servicing the inlet valve. Serious bodily injury can occur if valve is removed when the piping is pressurized. Keep head and body parts away from the rotor's exposed internal openings at all times. Wear proper eye protection and use the designated tools when servicing these rotors.*

### Tools Needed (varies with rotor model)

Once the riser assembly has been removed, the following tools are used to remove, service and replace inlet valves:

- G800 Valve Tool – PN 604000
- G900 Valve Tool – PN 280500
- Snap-Ring Tool – PN 251000
- 16" Needle-Nose Pliers Tool – PN 475600
- Manual Extraction Pump Tool – PN 460302
- TTS Valve Flushing Tool – PN 609400

### Valve Identification

It is important to note that there are different types of inlet valves (also commonly known as foot valves). If the incorrect inlet valve is installed, the rotor will malfunction. Hunter has a color-coding system to help correctly identify these valves:

G800C Check-O-Matic Rotors = Black screen attached to valve (fig 72)



Fig 72

G800E Electric V.I.H. Rotors = Tan screen attached to valve (fig 73)



Fig 73

G900C Check-O-Matic Rotors = Black screen attached to valve (fig 74)



Fig 74

G900E Electric V.I.H. Rotors = White screen attached to valve (fig 75)



Fig 75

**Warning:**

- *If a black screened inlet valve is installed into an electric valve-in-head rotor, the rotor will not shut off.*
- *If a tan or white screened inlet valve is installed into a check-o-matic rotor, the rotor will leak water from the vent port during sprinkler operation and, the check height will be negatively affected.*

**Caution! Electric valve-in-head rotors are connected to pressurized main-line or sub-main piping. This pressurized piping must be depressurized before servicing the inlet valve. Serious bodily injury can occur if valve is removed when the piping is pressurized. Keep head and body parts away from the rotor's exposed internal openings at all times. Wear proper eye protection and use the designated tools when servicing these rotors.**

**Inlet Valve Removal – Disengaging the Safety Interlock Feature**

With the main-line or sub-main depressurized and the riser assembly removed, proceed with disengaging the G800 inlet valve's safety interlock feature as follows:

Remove the water inside the rotor's body using manual hand pump. Look into the body cavity and take note of the white lower snap-ring and just below, the black top of the inlet valve (fig 76). The white snap ring may be stained from the water making it gray or brown colored (fig 77). To help prevent removal of the inlet valve with the main-line or sub-main pressurized, a safety interlock feature has been added to the white lower snap-ring. Before the white lower snap-ring and inlet valve can be removed, this safety interlock feature must be disengaged.



Fig 76



Fig 77

To disengage the safety interlock feature, place the tip of the 16" Needle-Nose Pliers Tool on top of the inlet valve. Next, press downward on the inlet valve. The inlet valve should move down slightly. If no movement is observed or felt, stop and confirm that the main-line or sub-main has been depressurized.

If main-line or sub-main has been shut off, it is possible that resident pressure is still within the line and this pressure is preventing the inlet valve from moving downward. To relieve this pressure, activate a near-by quick coupler or, turn the rotor's selector cap to the manual ON position. *Warning – rotor may activate for a brief period of time.* Use the 16" Needle-Nose Pliers Tool to press downward on the inlet valve again. The white lower snap-ring and inlet valve are now ready for removal.

### Inlet Valve Removal – G800 Series

With the main-line or sub-main depressurized, the riser assembly removed, the water extracted from the body cavity and the safety interlock feature disengaged, proceed with removal of the G800's white lower snap-ring and inlet valve as follows:

First, notice that close to each end of the white lower snap-ring there are two raised areas (fig 76). These two raised areas are used to remove the white lower snap-ring. Also notice that the inlet valve has two posts protruding upward on top of the inlet valve. Take a moment to note the orientation of these posts and how they nest within the white lower snap-ring. Understanding this alignment and orientation will help later to confirm that the white lower snap-ring has been properly seated after installation.

To remove the white lower snap-ring, use the 16" Needle-Nose Pliers Tool to grab the outer side of the two raised areas near the ends of the white lower snap-ring. Next, squeeze the two raised areas together with the tips of the 16" Needle-Nose Pliers Tool (fig 78). This action will collapse the white lower snap-ring. While holding the collapsed white lower snap-ring, pull the 16"needle-nose pliers up and out along with the white lower snap-ring (fig 79).



Fig 78



Fig 79

**Inlet valve removal option 1** – Once the white lower snap-ring has been removed, the inlet valve is released and is ready for removal. G800 Series inlet valves are removed from the body using the G800 Valve Tool. Prior to using the tool, familiarize yourself with the individual features of the G800 Valve Tool. First, notice there are two metal hooks at the bottom of the tool (fig 80). These hooks are used to grab/hook the inlet valve for removal from the rotor's body. The black plastic part of the G800 Valve Tool includes physical features that hold or nest the inlet valve to the tool during inlet valve removal and installation.

In order to engage the inlet valve with the G800 Valve Tool properly, you must be familiar with the pointing and alignment features on the tool's black plastic part. First, look at the three retaining screws on top of the tool. Next, find the screw that has a pointer arrow engraved around the head of the screw (fig 81). This pointer is used to indicate the direction and alignment that the tool must have as it is inserted into the rotor's body. A second pointer arrow is located directly below on the underside of the G800 Valve Tool (fig 82).

To remove the inlet valve, it is necessary to align the pointer arrow on the G800 Valve Tool with the alignment dot on the rotor's flange. The alignment dot is centered on the flange compartment lid adjacent to (next to) the body cavity opening (fig 81). A second alignment dot is located below the lid in case the flange compartment lid has been removed. Align the pointer arrow on the tool with the alignment dot and lower the tool into the rotor's body.

As the G800 Valve Tool is lowered into the rotor's body, recessed areas on the black plastic part on the tool will engage vertical rails inside the body wall (fig 83). The tool must engage these rails or the tool will not align with the inlet valve below. Continue pressing downward compressing the spring on the G800 Valve Tool. While holding the tool down with the spring compressed, turn the tool's handle clockwise until it stops. Next, release the spring's compression by lifting the handle slightly on the G800 Valve Tool. This action hooks and locks the inlet valve to the tool. Finally, pull upward on the tool's handle to remove the tool and inlet valve from the rotor's body (fig 84).



Fig 80



Fig 81



Fig 82



Fig 83



Fig 84



Fig 85

*Important* – Take note of how the G800 Valve Tool nests with the attached inlet valve. This will help later when attaching the inlet valve to the tool prior to inlet valve installation.

To disengage the inlet valve from the G800 Valve Tool, hold the inlet valve with one hand and the tool with the other hand. Next, push the tool's handle toward the inlet valve to compress the tool's spring (fig 85). With the spring held compressed, rotate the tool's handle counter-clockwise to release the tool's hooks from the inlet valve.

***Inlet valve removal option 2*** – Once the white lower snap-ring has been removed, the inlet valve is released and is ready for removal. First notice the raised wall or rib that protrudes upward from the center of the inlet valve (fig 86). Use the 16" Needle-Nose Pliers Tool to grab this protruding rib firmly. While holding the protruding rib firmly with the 16" Needle-Nose Pliers Tool, pull upward to disengage and remove the inlet valve from the rotor's body (fig 87).

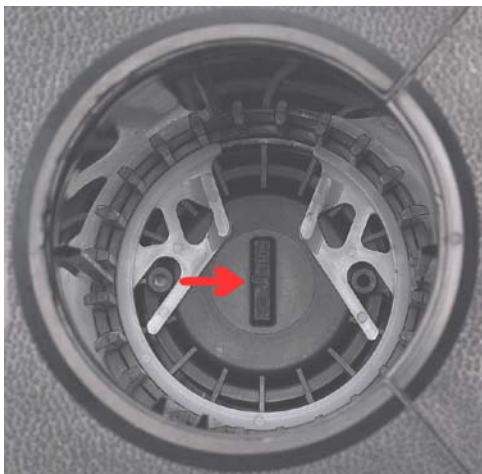

Fig 86



Fig 87

## Inlet Valve Removal – G900 Series

With the main-line or sub-main depressurized, the riser assembly removed, the water extracted from the body cavity and the safety interlock feature disengaged, proceed with removal of the G900's white lower snap-ring and inlet valve as follows:

First, notice that close to each end of the white lower snap-ring there are eyelets (areas with a hole for access). These two eyelets are used to remove the white lower snap-ring (fig 88).

To remove the white lower snap-ring, insert the metal end of the Snap-Ring Tool into one of the eyelets. Next, twist the Snap-Ring Tool's handle while forcing the tip of the tool towards the center of the rotor's body cavity (fig 89). This action will disengage one end of the white lower snap-ring from the recessed groove at the base of the rotor's body. With the white lower snap-ring disengaged from the groove, pull the tool upward to remove the white lower snap-ring (fig 90).



Fig 88



Fig 89



Fig 90

Once the white lower snap-ring has been removed, the inlet valve is released and is ready for removal. G900 Series inlet valves are removed from the body using the G900 Valve Tool. Prior to using the tool, familiarize yourself with the individual features of the G900 Valve Tool. First, notice there are hooks at the end of each metal bar (fig 91). These hooks are used to grab/hook the inlet valve for removal from the rotor's body. The black plastic part of the G900 Valve Tool includes physical features that hold or nest the inlet valve to the tool during inlet valve removal and installation.

In order to engage the inlet valve with the G900 Valve Tool properly, you must be familiar with the pointing and alignment features on the tool's black plastic part. First, look at the top inside diameter (inner circle) of the black plastic part on the tool. Next, find the small pointer arrow that protrudes towards the center (fig 92). This pointer is used to indicate the direction and alignment that the tool must have as it is inserted into the rotor's body.

Directly below the pointer on the underside of the G900 Valve Tool there are a series raised tabs. The tab directly below the pointer appears to be missing but this gap between tabs is intentional (it is designed to be this way). When the tool is nested to the valve, the gap provides clearance for the inlet valve's communication port (fig 93).



Fig 91



Fig 92



Fig 93

To remove the inlet valve, it is necessary to align the pointer arrow on the G900 Valve Tool with the alignment dot on the rotor's flange. The alignment dot is centered on the flange compartment lid adjacent to (next to) the body cavity opening. A second alignment dot is located below the lid in case the flange compartment lid has been removed. Align the pointer arrow on the tool with the alignment dot (fig 94) and lower the tool into the rotor's body (fig 95).

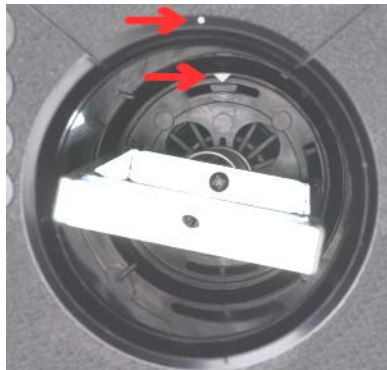

Fig 94



Fig 95



Fig 96

As the G900 Valve Tool is lowered into the rotor's body, recessed areas on the black plastic part on the tool will engage vertical rails inside the body wall. The tool must engage these rails or the tool will not align with the inlet valve below. Continue pressing downward compressing the spring on the G900 Valve Tool. While holding the tool down with the spring compressed, turn the tool's handle clockwise until it stops. Next, release the spring's compression by lifting the handle slightly on the G900 Valve Tool. This action hooks and locks the inlet valve to the tool. Finally, pull upward on the tool's handle to remove the tool and inlet valve from the rotor's body (fig 96).

*Important* – Take note of how the G900 Valve Tool nests with the attached inlet valve. This will help later when attaching the inlet valve to the tool prior to inlet valve installation.

To disengage the inlet valve from the G900 Valve Tool, hold the inlet valve with one hand and the tool with the other hand. Next, push the tool's handle toward the inlet valve to compress the tool's spring. With the spring held compressed, rotate the tool's handle counter-clockwise to release the tool's hooks from the inlet valve (fig 96).



Fig 96

## Inlet Valve Servicing – All Models

Inlet Valves (also commonly known as foot valves) do not have serviceable internal parts and the valves are welded together as an assembly. As a result, inlet valves cannot be taken apart. Any disassembly of an inlet valve will lead to a valve that is no longer usable.

Contamination within the inlet valve can cause the valve to leak. To remove contamination within the inlet valve, follow the procedures below:

Fill a bucket with clean water. Using the TTS Valve Flushing Tool, insert the stainless steel metal pins on the tool into the holes at the bottom of the inlet valve's screen (fig 97). While holding the TTS Valve Flushing Tool in the palm of one hand and the top of the inlet valve with the other hand, lower the inlet valve into the bucket of water. To clean & flush contamination from the valve, firmly push the tool into the valve (fig 98). Resistance will be felt as the valve's internal spring is compressed. Cycle the valve open & closed with the tool multiple times while holding it submerged in the bucket of water. Remove the valve from the water and inspect for any remaining contamination.



Fig 97



Fig 98

## Inlet Valve Installation – Safety Warnings

**Caution!** *If inlet valve (also commonly known as a foot valve) is not properly installed and held securely in place with a properly installed snap-ring, the inlet valve can be expelled from the rotor when the piping is re-pressurized. Serious bodily injury can occur. Keep head and body parts away from the rotor when piping is being re-pressurized.*

**Attention!** *Read and understand the inlet valve installation instructions outline below. If you are unsure or not clear on any portion of the installation procedure, contact your local Hunter Golf Distributor Representative or Hunter Technical Services can be contacted at 800-733-2823 and choose option #3.*

## Inlet Valve Installation – G800 Series

Remove excess water from the rotor's body cavity. Inspect the upper and lower snap ring grooves making sure there are no damaged or missing sections of plastic adjacent to (next to) the snap ring grooves. Remove all plastic shavings or burrs of plastic that are found within the body cavity.

If needed, a small amount of Dow Corning™ #111 Valve Lubricant or pure petroleum jelly like Vaseline™ can be used around the O-Ring on the inlet valve. In most instances, residual water within the rotor's body cavity is sufficient lubrication for inlet valve installation.

**Caution!** Use of other non-specified lubricants can attack and deteriorate the plastic used in golf rotors. Stress cracks or leaking caused by the use of improper lubricants are not covered under warranty.

**Inlet valve installation option 1** – G800 Series inlet valves are installed in the body using the G800 Valve Tool. Prior to using the tool, familiarize yourself with the individual features of the G800 Valve Tool. First, notice there are two metal hooks at the bottom of the tool (fig 99). These hooks are used to grab/hook the inlet valve during installation. The black plastic part of the G800 Valve Tool includes physical features that hold or nest the inlet valve and the white lower snap ring to the tool during installation.

In order to engage the inlet valve and white lower snap ring with the G800 Valve Tool properly, you must be familiar with the pointing and alignment features on the tool's black plastic part. First, look at the three retaining screws on top of the tool. Next, find the screw that has a pointer arrow engraved around the head of the screw (fig 100). This pointer is used to indicate the direction and alignment that the tool must have as it is inserted into the rotor's body. A second pointer arrow is located directly below on the underside of the G800 Valve Tool (fig 101).



Fig 99



Fig 100



Fig 101

The underside of the black plastic part on the G800 Valve Tool includes a feature that will hold the white lower snap ring in position during installation. The white lower snap ring must be oriented correctly in the tool and the raised areas at each end of the snap ring must be facing the black plastic part on the tool. The white lower snap ring must be loaded to the G800 Valve Tool correctly. If the snap ring is not loaded correctly, the valve cannot be loaded to the tool.



Fig 102



Fig 103

To install the inlet valve into the rotor's body, first load the white lower snap ring to the tool. Hold the white lower snap ring in the palm of one hand with the raised protruding ends of the snap ring facing towards you (fig 102). In the other hand hold the G800 Valve Tool with the metal hook end of the tool pointing towards you. Compress the snap ring and place onto the tool so that the two metal roll-pins at the bottom of the black plastic part of the tool hold and retain the white lower snap ring (fig 103).

With the white lower snap ring loaded to the underside of the G800 Valve Tool, load the inlet valve to the tool. To do so, hold the inlet valve in one hand with its top facing toward you (fig 104). Rotate the inlet valve in your hand so that the communication port (located on the side of the inlet valve) is at the 12:00 position while holding it in your hand. In the other hand, hold the G800 Valve Tool by the handle. The tool needs to be held so that the pointer arrow (located at one of the three screws on top of the tool) is also oriented to the 12:00 position.

Next, slightly rotate the tool counter-clockwise to the 11:30 position. This alignment will allow the two metal hooks on the G800 Valve Tool to pass through the two correct openings around the outside of the inlet valve. Press the metal hooks through the openings. Continue pressing the inlet valve and G800 Valve Tool together compressing the spring on the tool (fig 105). While holding the tool down with the spring compressed, turn the tool's handle clockwise until it stops. Next, release the spring's compression by lifting the handle slightly on the G800 Valve Tool. This action hooks and locks the inlet valve to the tool. Check to make sure that the pointer arrow on the tool is directly above the communication port on the inlet valve and that the valve is securely hooked to the tool.



Fig 104



Fig 105

Next, insert the assembled tool, white lower snap ring and inlet valve into the rotor's body cavity. To do so, it is necessary to align the pointer arrow on the G800 Valve Tool with the alignment dot on the rotor's flange. The alignment dot is centered on the flange compartment lid adjacent to (next to) the body cavity opening (fig 106). A second alignment dot is located below the lid in case the flange compartment lid has been removed. Align the pointer arrow on the tool with the alignment dot and lower the assembled tool, white lower snap ring and inlet valve into the rotor's body.

As the G800 Valve Tool is lowered into the rotor's body, recessed areas on the black plastic part on the tool will engage vertical rails inside the body wall (fig 107). The tool must engage these rails or the inlet valve's communication port will not align with the communication port in the body cavity below. Continue pressing the assembled tool, white lower snap ring and inlet valve downward into the rotor's body. Once the tool reaches the bottom, continue pressing firming to securely seat the inlet valve and snap ring.

A distinct "click" sound should be heard as the snap ring is released and engages the snap ring groove in the rotor's body cavity. After the inlet and white lower snap ring have been properly seated, press down on the tool then rotate counter-clockwise to disengage the tool's metal hooks from the inlet valve. Next, raise the G800 Valve Tool out of the body. Finally, take whatever time is necessary to visually confirm that every part of the white lower snap ring is securely seated into the snap ring groove.



Fig 106



Fig 107

***Inlet valve installation option 2*** – The alternative method to installing the G800 inlet valve is to use the 16” Needle-Nose Pliers Tool. First look at the top of the inlet valve and notice the raised wall or rib that protrudes upward from the center. During installation, the 16” Needle-Nose Pliers Tool is used to grab this protruding rib on the inlet valve. Next, look at the side of the inlet valve and notice the communication port. During installation, this communication port must engage the communication port at the bottom of the rotor’s body cavity. Now notice that directly above the communication port there is a slot feature on the valve’s outside ring (fig 108). During installation, this slot feature must engage the vertical rail of plastic located on the rotor body’s inside wall. The vertical rail is located directly above the communication port at the base of the rotor’s body cavity.

Grab the protruding rib on the inlet valve firmly with the 16” Needle-Nose Pliers Tool. Next, insert the inlet valve into the rotor’s body cavity. It is necessary to align the valve’s communication port and/or the slot feature with the alignment dot on the rotor’s flange (fig 109). The alignment dot is centered on the flange compartment lid adjacent to (next to) the body cavity opening. A second alignment dot is located below the lid in case the flange compartment lid has been removed.



Fig 108



Fig 109

With the valve's communication port and/or the slot feature aligned to the dot on top of the rotor, carefully lower the inlet valve into the rotor's body. If the inlet valve is properly engaged with the vertical rail in the body, it will not be possible to rotate the inlet valve. If the inlet valve can be rotated in either direction, pull the inlet out and start again. With the inlet valve engaging the body's vertical rail, continue lowering the valve into the rotor's body. It is important to keep the inlet valve vertical in order to allow the valve's rock screen to enter the inlet of the body. Once the inlet valve reaches the bottom, continue pressing firmly to securely seat the inlet valve.

Next, use the 16" Needle-Nose Pliers Tool to install the white lower snap ring. To do so, use the tool to grab the outer side of the two raised areas near the ends of the white lower snap-ring (fig 110). The snap ring must be installed with these two raised & protruding areas on the snap ring ends facing upward. Next, squeeze the two raised areas together with the tips of the 16" Needle-Nose Pliers Tool. This action will collapse the white lower snap-ring. While holding the collapsed white lower snap-ring with the tool, lower the white lower snap ring into the rotor's body (fig 111). Next, engage and release the snap ring into the snap ring groove located at the base of the body cavity wall. Finally, take whatever time is necessary to visually confirm that every part of the white lower snap ring is securely seated into the snap ring groove (fig 112).

**Caution!** If snap-ring is not fully seated in the snap-ring groove, the valve may be expelled from the rotor when the piping is re-pressurized. Serious bodily injury can occur. Keep head and body parts away from the rotor when piping is being re-pressurized.



Fig 110



Fig 111



Fig 112

### **Inlet Valve Installation – G900 Series**

Remove excess water from the rotor's body cavity. Inspect the upper and lower snap ring grooves making sure there are no damaged or missing sections of plastic adjacent to (next to) the snap ring grooves. Remove all plastic shavings or burrs of plastic that are found within the body cavity.

If needed, a small amount of Dow Corning™ #111 Valve Lubricant or pure petroleum jelly like Vaseline™ can be used around the O-Ring on the inlet valve. In most instances, residual water within the rotor's body cavity is sufficient lubrication for inlet valve installation.

**Caution!** Use of other non-specified lubricants can attack and deteriorate the plastic used in golf rotors. Stress cracks or leaking caused by the use of improper lubricants are not covered under warranty.

G900 Series inlet valves are installed in the body using the G900 Valve Tool. Prior to using the tool, familiarize yourself with the individual features of the G900 Valve Tool. First, notice there are hooks at the end of each metal bar (fig 113). These hooks are used to grab/hook the inlet valve during installation. The black plastic part of the G900 Valve Tool includes physical features that hold or nest the inlet valve and the white lower snap ring to the tool during installation.

In order to engage the inlet valve and white lower snap ring with the G900 Valve Tool properly, you must be familiar with the pointing and alignment features on the tool's black plastic part. First, look at the top inside diameter (inner circle) of the black plastic part on the tool. Next, find the small pointer arrow that protrudes towards the center (fig 114). This pointer is used to indicate the direction and alignment that the tool must have as it is inserted into the rotor's body.

Directly below the pointer on the underside of the G900 Valve Tool there are a series raise tabs (fig 115). The tab directly below the pointer appears to be missing but this gap between tabs is intentional (it is designed to be this way). When the tool is nested to the valve, the gap provides clearance for the inlet valve's communication port.



Fig 113



Fig 114



Fig 115

To install the white lower snap ring and inlet valve into the rotor's body, first load the white lower snap ring and valve to the tool. To do so, hold the valve in the palm of the hand as shown (fig 116). In the other hand, take the white lower snap ring. Notice the white lower snap ring has a step feature around the outside of the ring. The correct orientation for installation is to have the widest side facing down and the thinnest side facing up. To help with this orientation, the G900's white lower snap ring has engraving on the upper surface that says, "This side up." Next, place the snap ring on top of the G900 valve as shown (fig 116). Make sure that the snap ring's upper side (thinnest side) is facing upwards. Now rotate the snap ring so that the open ends of the snap ring are directly over the valve's communication port (fig 117). This prevents the metal bar on the valve tool from interfering with the seating of the snap ring in the body.



Fig 116

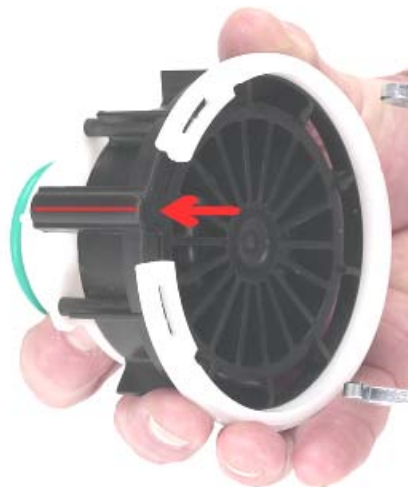

Fig 117

With the white lower snap ring resting on top of the valve as shown, load the inlet valve and snap ring to the valve installation tool. To do so, hold the inlet valve and snap ring in one hand with the top facing toward you. Rotate the inlet valve in your hand so that the communication port (located on the side of the inlet valve) is at the 12:00 position while holding it in your hand (fig 118). In the other hand, hold the G900 Valve Tool by the handle. The tool needs to be held so that the pointer arrow (fig 119) located on the inside of the ring at the top of the tool, is also oriented to the 12:00 position.

Next, slightly rotate the valve installation tool counter-clockwise to the 11:30 position. This alignment will allow the two metal hooks on the G900 valve tool to pass through the two correct openings around the outside of the inlet valve. Press the metal hooks through the openings. Continue pressing the inlet valve and G900 Valve Tool together compressing the spring on the tool. While holding the tool down with the spring compressed, turn the tool's handle clockwise until it stops (fig 120). Next, release the spring's compression by lifting the handle slightly on the G900 Valve Tool. This action hooks and locks the inlet valve to the tool.



Fig 118



Fig 119



Fig 120

Check to make sure that the pointer arrow on the tool is directly above the communication port on the inlet valve and that the valve is securely hooked to the tool (fig 120). Once the white lower snap ring and inlet valve have been properly secured to the tool, rotate the snap ring so that the snap ring's open ends are 180 degrees away from the pointer arrow (to the opposite side of the tool).

Next, insert the assembled tool, white lower snap ring and inlet valve into the rotor's body cavity. To do so, it is necessary to align the pointer arrow on the G900 Valve Tool with the alignment dot on the rotor's flange (fig 121). The alignment dot is centered on the flange compartment lid adjacent to (next to) the body cavity opening. A second alignment dot is located below the lid in case the flange compartment lid has been removed. Align the pointer arrow on the tool with the alignment dot and lower the assembled tool, white lower snap ring and inlet valve into the rotor's body.

As the G900 Valve Tool is lowered into the rotor's body, recessed areas on the black plastic part on the tool will engage vertical rails inside the body wall. The tool must engage these rails or the inlet valve's communication port will not align with the communication port in the body cavity below. Continue pressing the assembled tool, white lower snap ring and inlet valve downward into the rotor's body. Once the tool reaches the bottom, continue pressing firmly to securely seat the inlet valve and snap ring (fig 122).

A distinct "click" sound should be heard as the snap ring is released and engages the snap ring groove in the rotor's body cavity. After the inlet and white lower snap ring have been properly seated, press down on the tool then rotate counter-clockwise to disengage the tool's metal hooks from the inlet valve. Next, raise the G900 Valve Tool out of the body. Finally, take whatever time is necessary to visually confirm that every part of the white lower snap ring is securely seated into the snap ring groove.

**Caution! If snap-ring is not fully seated in the snap-ring groove, the valve may be expelled from the rotor when the piping is re-pressurized. Serious bodily injury can occur. Keep head and body parts way from the rotor when piping is being re-pressurized.**



Fig 121



Fig 122

## Solenoid, Pilot Valve & Regulator Servicing – All Electric VIH Models

**Caution! Electric valve-in-head rotors are connected to pressurized main or sub-main piping. This pressurized piping must be depressurized before servicing the rotor. This rotor will activate (turn on) if Solenoid is loosened or if Solenoid is removed or if Pilot Valve is removed or the supply tubing is cut. The velocity of the water stream and flows emitted from the rotor are high. Bodily injury can occur if the water stream hits the face, eyes, ears or other body parts. Keep head and body parts way from water stream. Wear proper eye protection and use the designated tools when servicing these rotors. Whenever possible, keep head and body parts away from the top of the rotor.**

### Tools Needed

- Phillips Screwdriver
- Flat Blade Screwdriver
- Hunter Wrench – PN 471720
- Tubing Clamp, Locking Forceps or ¼" Tube Retainer (to close pilot valve's inlet tubing)
- Side Cutters (Dikes) or Blade Cutter (to cut tubing)

### Access To Flange Compartment Components

Using a Phillips screwdriver, remove the two stainless steel screws that retain the flange compartment's lid (fig 123). A slot is located adjacent to the on-off-auto selector at the edge of the flange lid. Use a bladed screwdriver to pry the flange lid up (fig 124). Set the flange lid and screws aside. Factory installed flange compartment lids have a large recessed area that can be used for the application of yardage marker placards (fig 125). An optional flange compartment lid is available with a raised area for paint-filled engraving of the yardage marker (fig 126). This optional version is only available as a replacement part.



Fig 123



Fig 124



Fig 125



Fig 126

With the flange compartment lid removed and prior to disassembly, take time to note the orientation of the various components within the flange compartment (fig 127). This will be valuable later for reference during final assembly. In particular notice:

- How the solenoid wires fold over the top and to the flat side of the solenoid
- How, in the Auto position, the flat on the side of the solenoid faces to the outside
- How the pilot valve's fittings and connected tubing point in a specific direction
- How the pressure regulator is tucked into position within the compartment



Fig 127

### **Selector Cap Removal**

The Selector Cap turns the Solenoid when the user changes the ON-AUTO-OFF settings. Under normal operating conditions, the Selector Cap should not need replacement. The Selector Cap can become damaged if the incorrect tool is used to make ON-AUTO-OFF selection adjustments. Prior to removing the Selector Cap, notice that the Solenoid wires run over the top of the Solenoid and out of the Selector Cap on the side of the Solenoid that has the flat surface. Also note that the Solenoid wires are positioned side-by-side and not twisted. To remove the Selector Cap, simply lift it up and away from the Solenoid (fig 128).



Fig 128

### **Solenoid & Pilot Valve Assembly Removal**

In order to work on the Solenoid or the Pilot Valve, it is first necessary to remove the connected Solenoid and Pilot Valve assembly from the flange compartment. Prior to removal, take note of the orientation of the fittings and tubing that are attached to the Pilot Valve. This will help with final assembly later.

To remove the Solenoid and Pilot Valve from the flange compartment, grab the Solenoid and wiggle it back and forth while lifting upwards (fig 129). Pull the Solenoid and Pilot Valve assembly up and on top of the rotor's flange (fig 130).



Fig 129



Fig 130

## Solenoid & Servicing and Replacement

### *Preventing Sprinkler Activation –*

*See the warning above regarding rotor activation when Solenoid is loosened or removed.* There are three ways to prevent activation of the rotor when the Solenoid is removed from the Pilot Valve:

- The best and most effective way is to shut down the main line or the sub-main line that supplies water to the rotor that is being serviced. Be aware that residual pressure may reside in the system piping even after that valve has been closed. To purge residual pressure, activate a rotor or quick-coupler near to the rotor being serviced or, move the selector to the manual On position.
- A tubing clamp or locking forceps tool can be used to pinch the supply tube going into the Pilot Valve. The pressurized supply tube runs from the inlet area of the rotor and up into the flange compartment then is directly connected to the bottom fitting on the Pilot Valve (fig 131). Caution – care needs to be taken and an appropriate tool used so as to not damage the tubing as it is clamped closed. A leaking supply tube will cause the rotor to weep water while deactivated.
- A ¼" tubing retainer can be used to pinch the supply tube going into the Pilot Valve. Note that the tubing used within the TTS rotor's flange compartment is 1/8" tubing, NOT ¼" tubing. To do so, bend the supply tubing together and slide the tube retainer over the bent end to hold the tubing closed. The pressurized supply tube runs from the inlet area of the rotor and up into the flange compartment then is directly connected to the bottom fitting on the Pilot Valve (fig 131). Caution – care needs to be taken so as to not damage the tubing as it is bent closed. This procedure is not recommended in cold weather conditions. A leaking supply tube will cause the rotor to weep water while deactivated.

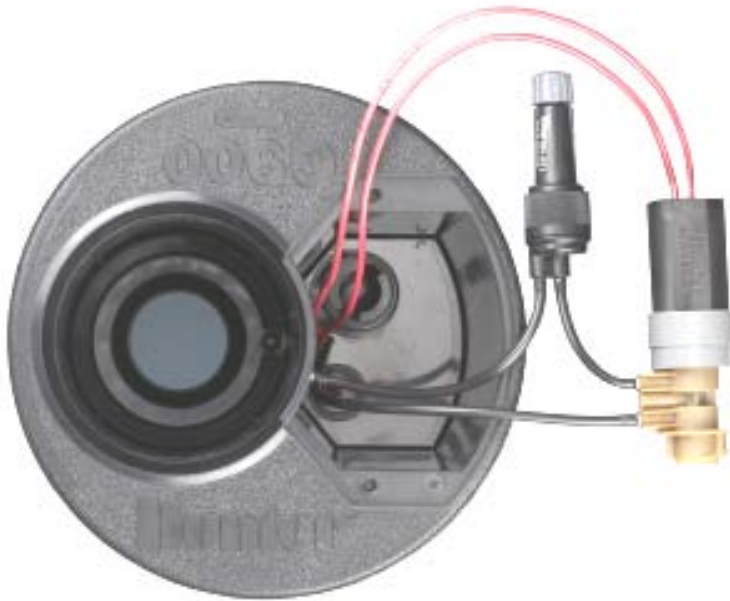

Fig 131

*Separate the Solenoid from the Pilot Valve* – Remove the Solenoid from Pilot Valve with counter-clockwise turns. Pull to separate the Solenoid from the Pilot Valve (fig 132). The gray plastic part at the base of the Solenoid is called the Detent Ring. When the Solenoid is attached to the Pilot Valve, the Detent Ring interacts with the Pilot Valve to create the Auto position's detent (the stopping point when moving the Selector Cap to the Auto position). Under normal operating conditions, the Detent Ring will not need replacement. If the solenoid needs to be replaced, it will also be necessary to replace the detent ring.



Fig 132

**Solenoid Servicing** – The Plunger assembly and the rubberized Seat-Seal are serviceable on Hunter Solenoids. To replace a worn or damaged rubberized Seat-Seal, simply pull the old one off and press the new one into position on the Solenoid's Plunger. Since a worn or damaged rubberized Seat-Seal can cause the rotor to weep water when the rotor is deactivated, it is highly recommended that the rubberized Seat-Seal be replaced whenever servicing the Plunger assembly.

The Plunger assembly is retained within the Solenoid with a secure snap-fit feature. To remove the Plunger assembly, first notice there is a Black Knurled Ring just below the Solenoid's rubberized Seat-Seal. Just below the Black Knurled Ring is a Black O-Ring. The Plunger assembly can be removed by forcing the thumb-nail under the Black Knurled Ring and pulling to separate the Plunger assembly from the Solenoid (fig 133). Alternatively, a small flat bladed screwdriver can be inserted below the Black Knurled Ring and twisted to release the Plunger assembly. Use care not to damage the Black O-Ring. If the Plunger assembly does not stay assembled when removed from the Solenoid, it is necessary to replace the Plunger assembly.

Rinse the Plunger assembly and Solenoid with clean water to remove any contaminating debris. If damage or worn, replace Black O-Ring and/or rubberized Seat-Seal (fig 134). Insert Plunger assembly into the Solenoid and then press to engage the snap-fit feature. Finally, press on the Seat-Seal to cycle the Plunger assembly. If plunger does not cycle up and down freely, repeat cleaning procedure and/or replace the Plunger assembly.



Fig 133



Fig 134

**Solenoid Replacement** – It is not necessary to dig around the rotor to replace in-ground Solenoid wire splice connections if there is confidence in both the quality of the splices and the type of connector used. It is absolutely not necessary to dig around the rotor to replace the Solenoid wire splice connections if the original connecting splices were completed within the rotor's flange compartment.

- *In-ground with questionable wire splice connections* – dig around the rotor to access the Solenoid splice connections. Remove the connectors. If possible, run controller wires into the rotor's flange compartment and splice wires to Solenoid's wires using appropriate grease-filled connectors. If not possible, feed replacement Solenoid's wiring through hole at the bottom of the flange compartment. Splice controller wires with Solenoid's wires using appropriate grease-filled connectors. Choose either of the Hunter DC Solenoid's lead wires when making each splice as there is no specific polarity required.

**IMPORTANT** – the TTS rotor’s top service capabilities required that there is sufficient slack of the Solenoid’s wiring leads within the flange compartment. To estimate required wiring slack, bring Solenoid to the top of the rotor’s flange. During back-fill of soil around rotor, do not let the Solenoid be pulled into the flange compartment.

- *In-ground good quality wire splice connections* – Hold the defective Solenoid in one hand and cut the defective Solenoid’s two lead wires at a point close to the defective Solenoid. Splice the lead wires from the defective Solenoid to the new Solenoid’s lead wires using appropriate grease-filled connectors. If needed, the new Solenoid’s lead wires can be shortened to minimize excess wiring within the flange compartment.
- *Flange compartment wire splice connections* – If original wire splice connections were made within the flange compartment, simply disconnect splices and re-splice controller wiring to the new Solenoid’s wiring leads. Confirm that appropriate grease-filled type connectors are in use. If not, discard and replace with appropriate connectors. If needed, the new Solenoid’s lead wires can be shortened to minimize excess wiring within the flange compartment.

### **Pilot Valve Replacement**

See the warning above regarding rotor activation when Solenoid is loosened or Pilot Valve tubing is disconnected. There are no serviceable parts within the TTS rotor’s Pilot Valve assembly. If the filter inside the Pilot Valve becomes obstructed, the water flow through the Pilot Valve can be reduced. A substantial reduction in water flow through the Pilot Valve will prevent the rotor’s Inlet Valve from opening fully.

Notice the two tubes attached to the Pilot Valve’s fittings (fig 135). The lower fitting is the inlet and the upper fitting is the outlet. The lower tube is the pressurized supply tube that comes from the rotor’s Inlet Valve at the bottom of the rotor. The upper tube goes from the Pilot Valve to the inlet of the Pressure Regulator. To replace the Pilot Valve, use side-cutters or blade to make clean cuts at points just before the fittings on the Pilot Valve. Trim & remove the remaining tube from fittings.

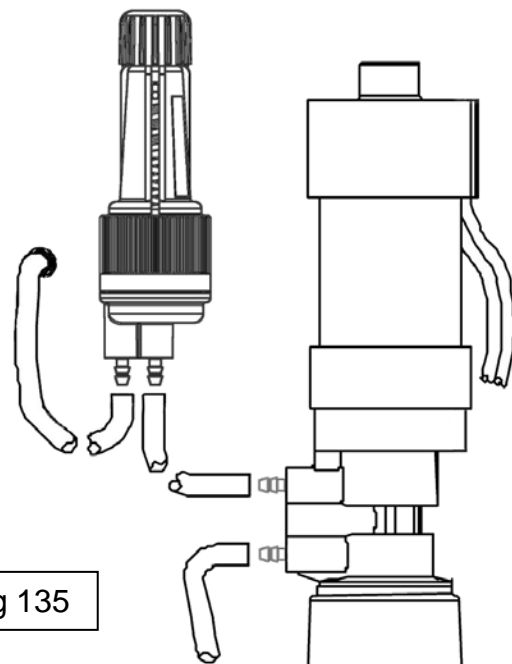

Fig 135

First connect the tube coming into the flange compartment from the bottom of the rotor. This tube must be connected to the lower fitting on the Pilot Valve. To connect, pinch tube's end with fingers in order to make the opening as round as possible. Place the tube at the end of the fitting then press and wiggle into position. Make sure the tube goes all the way to the base of the fitting. Next, connect the tube going to the Pressure Regulator. This tube must be connected to the Pilot Valve's upper fitting.

### Connecting Solenoid to the Pilot Valve

*To ensure that the On-Off-Auto feature functions properly, follow the procedure outlined below. The TTS rotor's Solenoid has double-lead threads. If this procedure is not followed, the Solenoid can be attached to the Pilot Valve 180 degrees out of position. While the On-Off-Auto feature will function if connected out of position, it will function much better if connected correctly.*

First, notice that there is a flat section on one side of the Solenoid (fig 136). This "flat" is used as a reference when connecting the Solenoid to the Pilot Valve. Next, notice there is also a flat section along the side of the Pilot Valve at a point opposite of the upper fitting. This "flat" is the second reference when connecting the Solenoid to the Pilot Valve.



Fig 136



Fig 137

With the gray Detent Ring attached to the bottom of the Solenoid, bring the Solenoid and the Pilot Valve together. Prior to engaging the Solenoid and Pilot Valve threads, align the flats on the Solenoid and Pilot Valve then press together. Prior to turning Solenoid clockwise, you must first turn the Solenoid counter-clockwise  $1/8^{\text{th}}$  of a turn. This action ensures that the correct first thread on Solenoid engages the first thread on the Pilot Valve. Now press the Solenoid & Pilot Valve together while threading the Solenoid clockwise onto the Pilot Valve.

Next, the Solenoid must be placed in the Auto position. To do so, keep turning the Solenoid clockwise onto the Pilot Valve until it stops (bottoms out). **Do not tighten!** Then, turn the Solenoid counter-clockwise until you feel the first Detent Ring click (fig 137). This is the Auto position.

To check for proper alignment, position the connected Solenoid and Pilot Valve assembly in your hand so you are looking at the top. Next, rotate the Solenoid and Pilot Valve assembly until the “flat” on the Solenoid is at the 12:00 position (do not unthread Solenoid from Pilot Valve). With the Solenoid’s flat in the 12:00 position, the Pilot valve’s fittings should be at the 3:00 position. If the fittings are not at the 3:00 position, disconnect and repeat the procedure.

### **Attaching the Assembled Solenoid and Pilot Valve to the Flange Compartment**

With the Solenoid and Pilot Valve correctly assembled as outlined above, look at the bottom of the Pilot Valve. Notice there are two opposing sections of plastic that protrude to the outside and away from the center (fig 138). These two “ears” must engage the Pilot Valve’s mounting base in the body flange compartment during installation (fig 139).



Fig 138



Fig 139

To install the Solenoid and Pilot Valve, first position yourself to the side of the rotor such that the rotor’s flange compartment is at the 6:00 position (closest to you). Next, lower the Solenoid and Pilot Valve assembly (fig 140) into the flange compartment with the Pilot Valve’s fittings pointing to the left side (9:00 position). Engage the bottom of the Pilot Valve with the Pilot Valve’s mounting base located at the right and rear of the flange compartment. Press down to engage Pilot Valve’s mounting ears (fig 141).



Fig 140



Fig 141

### Attaching Selector Cap to the Solenoid

The Selector Cap turns the Solenoid when the user changes the ON-AUTO-OFF settings. Under normal operating conditions, the Selector Cap should not need replacement. The Selector Cap can become damaged if the incorrect tool is used to make ON-AUTO-OFF selection adjustments.

With the Solenoid and Pilot Valve assembly installed in the flange compartment and the Solenoid set to the Auto position (see instructions above), proceed as follows. The flat side of the Solenoid should be facing away from the rotor's riser assembly pointing towards the outside of the flange compartment (fig 141).



Fig 142



Fig 143

Starting from where the Solenoid's lead wires come out of the top of the Solenoid, place the lead wires side-by-side over the top and down the flat side of the Solenoid (fig 142). While hold the Solenoid's lead wires in this position, place the Selector Cap on top of the Solenoid. The Selector Cap must be oriented such that the Solenoid's lead wires fit into the recessed channel on the inside wall of the Selector Cap. Press the Selector Cap down and onto the Solenoid (fig 143).

### **Pressure Regulator Purpose, Settings and Adjustment Procedures**

Regulation settings are preset at the factory. If the installed rotor has been preset to the specified regulation setting for your irrigation system, further Pressure Regulator adjustments are not normally necessary. If a replacement TTS rotor is being installed, it may be necessary to adjust the regulation setting.



Fig 144

*Pressure Regulator Purpose* – The purpose of the Pressure Regulator (fig 144) is to ensure that a specifically set pressure is supplied to the rotor's nozzles. Since the amount of flow through the nozzles is affected by pressure, supplying a consistent pressure to every rotor in the irrigation system is beneficial. This will help to ensure that all rotors with the same size nozzles will have the same application rate (also known as the precipitation rate).

Pressure regulation also prevents too much pressure from reaching the nozzles. Rotors that are closer to the pump station or rotors that are at lower elevation will have relatively higher pressures than rotors that are at the far reaches of the irrigation system's piping or those at higher elevations. Abnormally high pressures at the nozzles can cause misting of the water droplets. Water that is misting will be easily carried away from its intended target by the wind.

*Pressure Regulator Settings* – All electric valve-in-head TTS rotors have adjustable Pressure Regulators. One of the many beneficial features of TTS rotor is the fact that the Pressure Regulation is conveniently adjustable yet hidden within the flange compartment. This prevents untrained personnel or unknowing golfers attempting to shut down a running rotor from inadvertently changing the rotor's regulation setting.

## Pressure Regulator Adjustment

The variable setting Pressure Regulator has been calibrated from the factory and set to a specific regulation setting. This setting will not normally need to be changed. The variable Pressure Regulator has a pointer and a pressure indicating scale on the side of its body with a range of 60psi to 120psi. If pressure setting adjustments are required it is important to note the following:

- The calibrated pressure setting from the factory is very accurate. However, the pressure indicating scale is only a pressure setting reference when making adjustments in the field. For more precise pressure regulation adjustment in the field, use a pitot gauge at the nozzle to check pressure.

To raise the pressure setting on the variable setting regulator, turn the adjusting knob clockwise (fig 145). Each full turn clockwise of the adjusting knob will increase the pressure approximately 10psi. Use the scale on the side of the regulator's body to estimate pressure.



Fig 145

To lower the pressure setting on a variable setting regulator, turn the knob counter-clockwise (fig 145). To obtain more accurate setting when reducing the pressure, it is highly recommended that the setting be taken down to approximately 10psi below the desired pressure setting and then turn the knob clockwise to the desired setting.

## Pressure Regulator Replacement

To replace the Pressure Regulator, first disengage the Solenoid and Pilot Valve from the flange compartment. This action will create easier access to the Pressure Regulator. Next, notice the two tubes that are connected at the base of the Pressure Regulator (fig 146). The tube entering the center of the Pressure Regulator is the inlet and it comes from the top fitting in the Pilot Valve. The tube that is offset from the center is the outlet and it goes to the rotor's body wall. One of the TTS rotor's valuable features is that the water discharged from the valve circuitry is vented into the rotor's body and then out the nozzles.

To replace the Pressure Regulator, use side-cutters or blade to make clean cuts in the tubing at points just before they enter into the Pressure Regulator. Next, connect the inlet tube going into the center of the new Pressure Regulator. To connect, pinch tube's end with fingers in order to make the opening as round as possible. Place the end of the tube to the Pressure Regulator's center connection point then press and wiggle into position. Make sure the tube goes in as far as possible. Next, connect the outlet tube going to the rotor's body wall. If removed, attach the Solenoid and Pilot Valve to the flange compartment. Finally, insert Pressure Regulator into any convenient available location within the flange compartment.

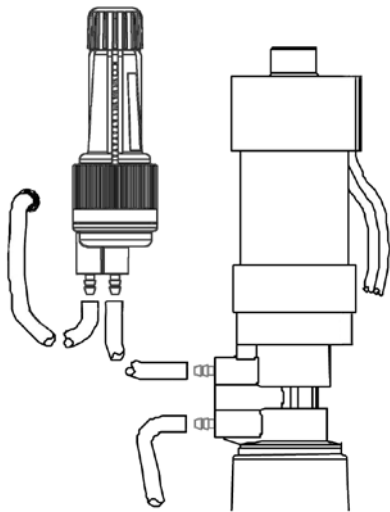

Fig 146



Fig 147

## Attaching the Flange Compartment Lid

Take a moment for a final check to make sure that all of the flange compartment components have been installed properly. Place the flange compartment lid into position and align the Selector Cap to its hole in the lid. Press the flange compartment lid into position and secure with the stainless steel retaining screws. Finally, check Selector Cap for free movement of the On-Off-Auto feature.

**If you have further questions after reviewing this manual, please contact Hunter's Technical Services Department at 800-733-2823 and select option #3.**