

SR75 BIG GUN® OPERATION & MAINTENANCE INSTRUCTIONS

SET UP FOR OPERATION:

1. Install desired Taper Ring size in ring nozzle cap. The ring nozzle cap can be sufficiently tightened by hand.
2. Adjust location of stops to give desired arc of coverage. Stops must be mounted so that arrows point toward each other and trip lever is located between arrows. If the stops are set incorrectly on the wrong end of the arc, the sprinkler will fail to reverse.

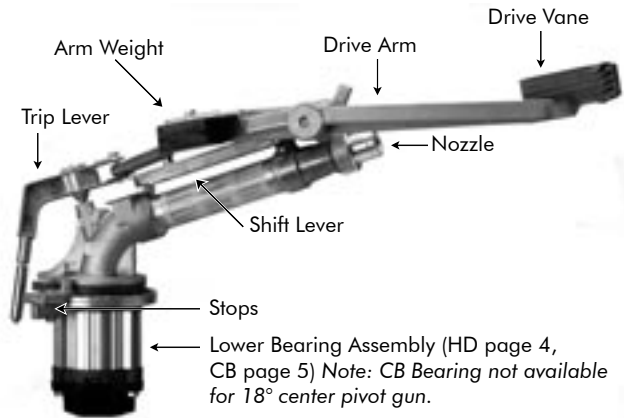

NOTE ON LUBRICATION:

The SR75 sprinkler is lifetime lubricated and does not require periodic lubrication. The ball bearings in the HD lower bearing operate in a water resistant lubricant that is packed in the housing cavities and retained by seals. If repair of the lower bearing is done, it is recommended to use Nelson #6143 lubricant or a good grade of water resistant lubricant such as Lubriplate 130-AA.

The **SR75** is available in fixed trajectory angles of **18°, 21°, 24°, 43°**

CAUTION: Read operating instructions before operating sprinkler or making any adjustments. Never make adjustments or perform service while sprinkler is in operation. Stand clear of operating sprinkler. Stand clear of high velocity water stream. Never direct water stream onto roadway or electrical transmission lines.

SR75 DRIVE ARM ASSEMBLY COMPONENTS

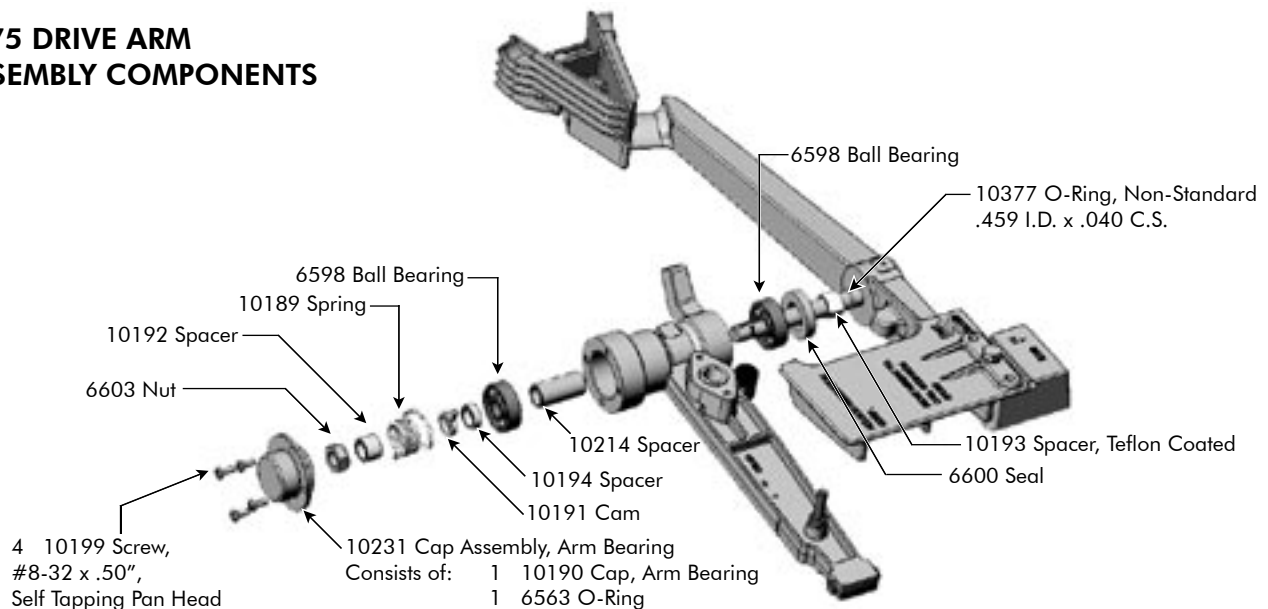

SEE FRONT FOR DRIVE ARM ASSEMBLY COMPONENTS / SEE SR75 PARTS LIST FOR COMPLETE PARTS LIST AND DESCRIPTIONS

DISASSEMBLY



STEP 1 (Trip Lever)
 Remove two #8311 screws and #10185 cap.



STEP 6
 Holding the range tube, pull drive arm from the right side until it is free from hub.



STEP 2
 Using small retaining ring pliers, remove #8323-201 ring.



STEP 7
 Inspect both left and right #6598 ball bearings. Replace if worn or corroded. Inspect #6600 seals as well. Lubricate seal with silicon grease prior to reassembly.



STEP 3
 Remove one #8311 screw from the shift stop bracket. Rotate the trip lever to pull follower from spring guide. Pull entire trip lever assembly from gun. Inspect wear on the #8282 follower and #8193 pin.



STEP 8 (Shift Lever)
 Remove two #8311 screws and the #10364 cap. Using retaining ring pliers, remove #8323-212 ring.



STEP 4 (Drive Arm)
 Remove four #10199 screws. Remove #10231 cap.



STEP 9
 Pull #10226-004 shift lever from mount. Inspect the mount shaft and shift lever bushing for wear.

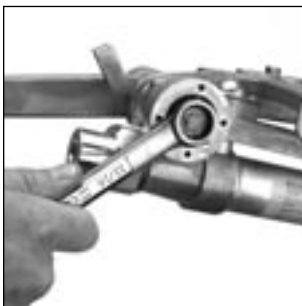

STEP 5
 Using an 11/16" socket, remove the #6603 nut from left side of arm.

SEE FRONT FOR DRIVE ARM ASSEMBLY COMPONENTS / SEE SR75 PARTS LIST FOR COMPLETE PARTS LIST AND DESCRIPTIONS

REASSEMBLY

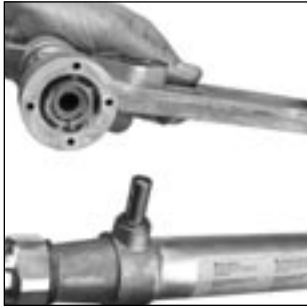

STEP 1 (Shift Lever)

Slide #10226-004 shift lever onto mount. Snap the #8323-212 retaining ring onto the mount. Replace the #10364 cap and the two #8311 screws.



STEP 6

Replace the #10231 cap making sure that the notch on the #10231 engages the spring tab on the #10189.



STEP 2 (Drive Arm)

Assure the #10377 O-ring and #10193 spacer is on the drive arm shaft. Push the shaft all the way into the right arm hub. From the left side slide onto the arm shaft, in sequence, the #10214 spacer, #6598 bearing, #10194 spacer, #10191 cam.



STEP 7

Replace the 4 #10199 screws. Make sure the drive arm rotates freely and returns to its at-rest position.



STEP 3

Make sure the #10191 cam is correctly keyed into the slot on the drive arm shaft. Notice the correct orientation of the finger on the cam for proper arm operation.



STEP 4

Continue the sequence of sliding onto the drive arm shaft the #10192 spacer and the #10189 spring. Notice the hook end of the spring goes in first so the spring wire loops around the finger of the #10191 cam.



STEP 5

Thread on #6603 nut. Torque to 25 ft. lbs. using the 1¹/₁₆" socket (metric torque = 34 NM or 3.5 MKG). Replace the lubricant.

SEE SR75 PARTS LIST FOR PARTS INFORMATION

DISASSEMBLY (HD LOWER UNIT)

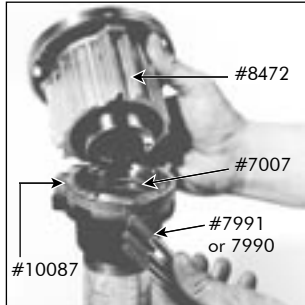

STEP 1
 Remove three #7990 or #7991 bolts from flange. Separate #8472 housing from #10087 Spacer Assembly. Remove #7007 O-Ring from #10087 Spacer Assembly.



STEP 2
 Place #6997 Lip Seal into #6858 cover as shown with Nelson name toward ball bearing. Pack #6559 Bearing with #6143 lubricant or equivalent. (See "Notes on Lubrication" on the front cover.) Press bearing into #6858 Cover. Slide cover assembly onto bearing shaft. CAUTION: Do not get grease on brake surfaces. To clean plastic brake, use soap and water (solvents may damage plastic). Clean #6858 cover with acetone.

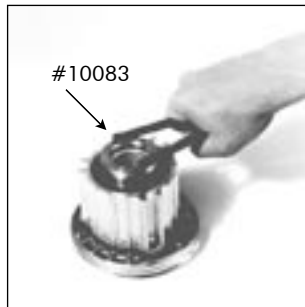

STEP 2
 The #10083 Retainer Assembly is removed by using spanner wrench. To hold the #7031 Shaft Assembly from rotating insert two 5/16-18 bolts (#6635) into shaft top. Clamp bolt heads into a vise securely. Remove retainer and #8472 Housing from bearing shaft.

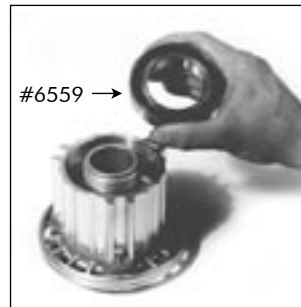

STEP 3
 Assemble #6566 Gasket. Press on #8472 Housing. Fully pack housing with #6143 Lubricant. Assemble #6559 Bearing into housing.



STEP 3
 Remove the #6998 Seal. To remove the two #6559 Bearings use a hammer and three blocks of wood. Lightly tap uniformly around inner race of bearing until removed. Bearings are removed from opposite sides of the #8472 Housing.

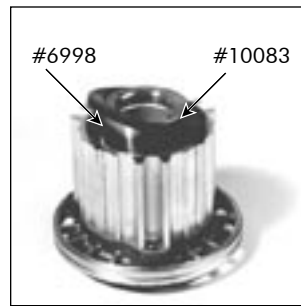

STEP 4
 Install #6999 O-Ring in #7003 Retainer and assemble retainer on shaft. Using method described in disassembly (Lower Unit) instructions Step 2, secure bearing shaft from rotating. Torque Retainer to 95-110 ft. lbs. Apply a light coating of #9673 Silicone Grease to O.D. of Retainer. Assemble #6998 Lip Seal. Orient with lip side out. Metric Torque = 129-149 NM or 13-15 MKG.

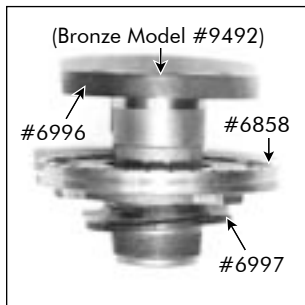

STEP 4
 Remove #6585 Cover from shaft. Remove #6997 Seal from cover. Remove #6996 Brake Ring and #7009 Dust Seal from shaft.

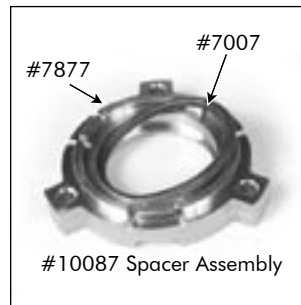

STEP 5
 Fully coat #7007 O-Ring with #9673 Silicone Grease & #9680 Graphite. Install prepared O-Ring into #7877 Spacer and mount onto assembly.

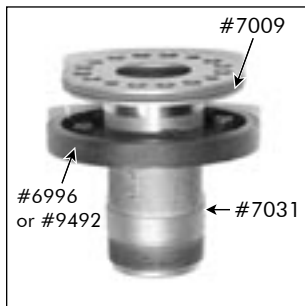

REASSEMBLY (HD LOWER UNIT)
STEP 1
 Assemble #7009 Dust Seal onto #7031 Shaft Assembly. Slide #6996 Brake Ring onto shaft. Locate the four studs of the brake ring in the center holes between the smaller threaded holes.



STEP 2
 Assemble #8967 O-Ring into the Flange Adapter. Mount Flange Adapter using required Bolts. Torque Bolts to 130-150 inch pounds.

SEE SR75 PARTS LIST FOR PARTS INFORMATION

DISASSEMBLY (CB LOWER UNIT)



STEP 1
 Remove three #6010 screws.
 Remove 10088-xxx Flange
 Assembly Connection.



STEP 6
 Remove the #6996 Brake Ring
 from the #10696 Adapter
 Assembly. Inspect all parts
 for wear and replace as
 required.



STEP 2
 To prevent the #10696 Adapter
 assembly from rotating insert two
 5/16-18 bolts into the adapter's
 threaded holes. Clamp bolt
 heads securely into a vice.

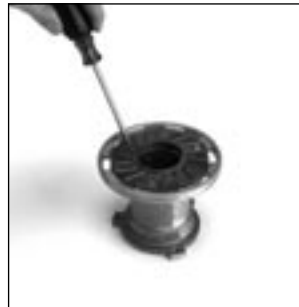

STEP 7
 Remove three #10706 screws.



STEP 3
 Place a .25" thick by 2.25"
 wide piece of steel in the slot of
 the #10719 Nipple Bearing.
 Remove the #10719 Nipple
 Bearing by holding the piece of
 steel with a wrench and slowly
 unthreading from the #10696
 Adapter Assembly.



STEP 8
 Remove the #10698 Wear
 Ring. Inspect the Wear Ring
 for wear and replace as
 required.



STEP 4
 Remove #10719 Nipple Bearing,
 #10701 Washer and #10699,
 #10700 and #10705 Seals.
 Inspect all parts for wear and
 replace as required.



STEP 9
 Remove the #6997 Upper
 Seal. Inspect the seal for wear
 and replace as required.



STEP 5
 Remove #10717 Housing
 Assembly from the #6996
 Brake Ring and #10696 Adapter
 Assembly. Inspect Sleeve Bearing
 #10717 for wear and replace as
 required.

SEE SR75 PARTS LIST FOR PARTS INFORMATION

REASSEMBLY (CB LOWER UNIT)



STEP 1

Slide the #6996 Brake Ring on to the #10696 Adapter Assembly. Each lug on the #6996 should slide into the middle hole between any two-threaded holes.



STEP 4

To prevent the #10696 Adapter assembly from rotating insert two 5/16-18 bolts into the adapter's threaded holes. Clamp bolt heads securely into a vice.



STEP 2

Insert #6996 Brake Ring and #10696 Adapter Assembly into #10717 Housing Assembly.

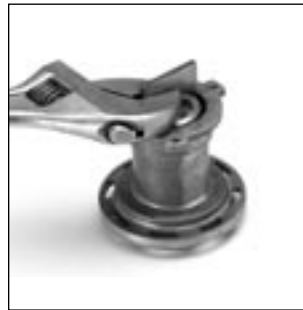

STEP 5

Place a .25" thick by 2.25" wide piece of steel in the slot of the 10719 Nipple Bearing. Reassemble the 10719 Nipple Bearing by holding the piece of steel with a wrench and slowly tightening into the 10696 Adapter Assembly to a torque of 90 ft-lbs.



STEP 3

Insert #10719 Nipple Bearing, #10701 Washer and #10699, #10700 and #10705 Seals into Assembly. Start threading the #10719 Nipple bearing into the #10696 Adapter Assembly by hand.



STEP 6

Place #6010 screws into #10088-xxx Flange Assembly Connection and tighten.

WARRANTY AND DISCLAIMER: Nelson Big Gun® Sprinklers are warranted for one year from date of original sale to be free of defective materials and workmanship when used within the working specifications for which the products were designed and under normal use and service. The manufacturer assumes no responsibility for installation, removal or unauthorized repair of defective parts. The manufacturer's liability under this warranty is limited solely to replacement or repair of defective parts and the manufacturer will not be liable for any crop or other consequential damages resulting from defects or breach of warranty. THIS WARRANTY IS EXPRESSLY IN LIEU OF ALL OTHER WARRANTIES, EXPRESS OR IMPLIED, INCLUDING THE WARRANTIES OF MERCHANTABILITY AND FITNESS FOR PARTICULAR PURPOSES AND OF ALL OTHER OBLIGATIONS OR LIABILITIES OF MANUFACTURER. No agent, employee or representative of the manufacturer has authority to waive, alter or add to the provisions of this warranty, nor to make any representations or warranty not contained herein. This product may be covered by one or more of the following U.S. Patent Nos. D297,453, 3,559,887, 3,744,720, 4,193,548, 4,669,663 and other U.S. Patents pending or corresponding issued or pending foreign patents.